

MIG/MAG



Product Catalogue 3.0 / V1



Content

MIG/MAG Welding Torches

- | | | |
|---|------|-------|
| ■ MIG/MAG Welding Torches "MB GRIP" air cooled (up to 230 A)
MB GRIP 15 AK / 25 AK | Page | 04-05 |
| ■ MIG/MAG Welding Torches "MB GRIP" air cooled (up to 320 A)
MB GRIP 24 KD / 26 KD / 36 KD | Page | 06-07 |
| ■ MIG/MAG Welding Torches "MB GRIP" liquid cooled (up to 550 A)
MB GRIP 240 D / 401 D / 401 / 501 / 501 D | Page | 08-09 |
| ■ MIG/MAG Welding Torches "MB ERGO" air and liquid cooled (up to 550 A)
MB ERGO 15 AK / 15 AK FX / 24 KD / 25 AK / 25 AK FX / 26 KD / 36 KD / 240 D / 401 / 401 D / 501 / 501 D | Page | 10-11 |
| ■ MIG/MAG Welding Torches "ABIMIG® GRIP" air cooled (up to 270 A)
ABIMIG® GRIP A 155 LW / 255 LW | Page | 12-13 |
| ■ MIG/MAG Welding Torches "ABIMIG® GRIP" air cooled (up to 430 A)
ABIMIG® GRIP A 305 LW / 355 LW / 405 LW | Page | 14-15 |
| ■ MIG/MAG Welding Torches "ABIMIG® A T LW" liquid cooled (up to 240 A)
ABIMIG® A T 155 LW / 255 LW | Page | 16-17 |
| ■ MIG/MAG Welding Torches "ABIMIG® A T LW" air cooled (up to 400 A)
ABIMIG® A T 305 LW / 355 LW / 405 LW | Page | 18-19 |
| ■ MIG/MAG Welding Torches "ABIMIG® GRIP" liquid cooled (up to 575 A)
ABIMIG® GRIP W 555 D / 555 D TS / 555 | Page | 20-21 |
| ■ MIG/MAG Welding Torches "ABIMIG® GRIP" liquid cooled (up to 625 A)
ABIMIG® GRIP W 605 / 605 D / 605 C | Page | 22-23 |
| ■ MIG/MAG Welding Torches "Push-Pull Plus" air and liquid cooled (up to 350 A)
PP Plus 36 D / 240 D / 401 D | Page | 24-25 |
| ■ MIG/MAG Fume Extraction Torches "RAB GRIP" air and liquid cooled (up to 550 A)
RAB GRIP 15 AK / 24 KD / 25 AK / 36 KD / 240 D / 501 / 501 D | Page | 26-27 |
| ■ Fume Extraction System
FES-200 / FES-200 W3 | Page | 28-29 |
| ■ MIG/MAG Machine Welding Torches air and liquid cooled
AUT / ABIMIG® MT | Page | 30-31 |

Spare Parts

- | | | |
|--|------|-------|
| ■ Bikox®, Control Cables, Hoses, Handles, Modules and Liners | Page | 32-37 |
|--|------|-------|

Central adaptor and central connector system

- | | | |
|--------------------------------|------|-------|
| ■ The universal connection ... | Page | 38-41 |
|--------------------------------|------|-------|

Central adaptor with spring contacts

- | | | |
|------------------------|------|----|
| ■ Flexible contact ... | Page | 42 |
|------------------------|------|----|

MIG/MAG Welding Torches "MB GRIP" air cooled

Rating 150 A up to 230 A

The MIG/MAG Torch series "MB GRIP", in air and liquid cooled varieties is the finest solution of its kind. It combines progressive technology and quality with optimum ergonomics, enabling trouble-free operation for every application.

"GRIP" insert and ball joint in the handle guarantees high grip safety as well as optimal handling. All torches are carefully designed to provide comfortable and precise operation.

- Ergonomic short handle with "GRIP" insert – for best accessibility
- "GRIP" soft components on the handle and thumb rest – positive handling even in extreme conditions
- Short ball joint with optimum movement radius – perfect handling
- Optimum cooling of the torch – extending torch life
- Bikox® R air cooled torches – high flexibility even at low temperatures, extremely UV resistant, considerably increased temperature resistance and tensile strength
- Time saving torch change over due to the ABICOR BINZEL central connector



MB GRIP 15 AK

Technical data (EN 60 974-7):

Rating:	180 A CO ₂ 150 A Mixed Gases M21 (DIN EN 439)
Duty cycle:	60%
Wire size:	0.6 – 1.0 mm

MB GRIP 25 AK

Technical data (EN 60 974-7):

Rating:	230 A CO ₂ 200 A Mixed Gases M21 (DIN EN 439)
Duty cycle:	60%
Wire size:	0.8 – 1.2 mm

Torch complete Type	Handle	Part-No.			Swan neck	
		3 m	4 m	5 m	Type	Part-No.
MB GRIP 15 AK	Type "MB GRIP"	002.0604	002.0605	002.0606	50°	002.0009
MB GRIP 25 AK	Type "MB GRIP"	004.0510	004.0511	004.0512	50°	004.0012

MB GRIP 15, MB GRIP 25

Wear parts

MB GRIP 15 AK

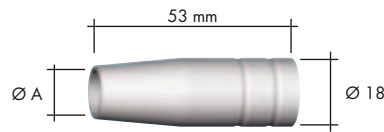

MB GRIP 25 AK

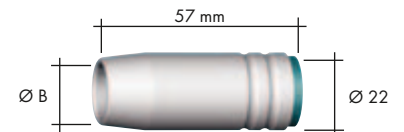

Gas nozzle (10 pcs.)

	Ø A		Ø B	
Cylindrical	Ø 16	145.0041	Ø 18	145.0042
Conical	Ø 12	145.0075	Ø 15	145.0076
Conical	Ø 9.5	145.0123	Ø 11.5	145.0124

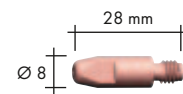
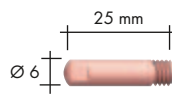

Contact tip (10 pcs.)

		M6	M6
E-Cu	Ø 0.6	140.0008	-
	Ø 0.8	140.0059	140.0051
	Ø 1.0	140.0253	140.0242
	Ø 1.2	-	140.0379
E-Cu for Al	Ø 0.8	141.0002	141.0001
	Ø 1.0	141.0007	141.0006
	Ø 1.2	-	141.0010
CuCrZr	Ø 0.6	140.0855	-
	Ø 0.8	140.0062	140.0054
	Ø 1.0	140.0256	140.0245
	Ø 1.2	-	140.0382

Nozzle spring (100 pcs.)

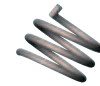

	002.0058	003.0013
--	----------	----------

Gas nozzle holder / Contact tip holder

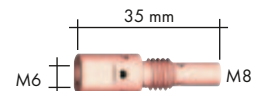

M6	002.0078	142.0001 (10 pcs.)
----	----------	--------------------

Liner	for 3 m				for 4 m				for 5 m			
	Insulated liner	Ø 0.6	124.0011	124.0011	124.0011	Ø 0.6	124.0012	124.0012	124.0012	Ø 0.6	124.0015	124.0015
PTFE liner	Ø 0.8	124.0011	124.0011	124.0011	Ø 0.8	124.0012	124.0012	124.0012	Ø 0.8	124.0015	124.0015	124.0015
	Ø 1.0	124.0026	124.0026	124.0026	Ø 1.0	124.0031	124.0031	124.0031	Ø 1.0	124.0035	124.0035	124.0035
	Ø 1.2	124.0026	124.0026	124.0026	Ø 1.2	124.0031	124.0031	124.0031	Ø 1.2	124.0035	124.0035	124.0035
	Carbon	Ø 0.6	126.0005	126.0005	126.0005	Ø 0.6	126.0008	126.0008	126.0008	Ø 0.6	126.0011	126.0011
PTFE liner	Ø 0.8	126.0005	126.0005	126.0005	Ø 0.8	126.0008	126.0008	126.0008	Ø 0.8	126.0011	126.0011	126.0011
	Ø 1.0	126.0021	126.0021	126.0021	Ø 1.0	126.0026	126.0026	126.0026	Ø 1.0	126.0028	126.0028	126.0028
	Ø 1.2	126.0021	126.0021	126.0021	Ø 1.2	126.0026	126.0026	126.0026	Ø 1.2	126.0028	126.0028	126.0028
	Carbon	Ø 0.6	127.0002	127.0002	127.0002	Ø 0.6	127.0003	127.0003	127.0003	Ø 0.6	127.0004	127.0004
PTFE liner	Ø 0.8	127.0002	127.0002	127.0002	Ø 0.8	127.0003	127.0003	127.0003	Ø 0.8	127.0004	127.0004	127.0004
	Ø 1.0	127.0005	127.0005	127.0005	Ø 1.0	127.0007	127.0007	127.0007	Ø 1.0	127.0008	127.0008	127.0008
	Ø 1.2	127.0005	127.0005	127.0005	Ø 1.2	127.0007	127.0007	127.0007	Ø 1.2	127.0008	127.0008	127.0008



MIG/MAG Welding Torches "MB GRIP" air cooled

Rating 220 A up to 320 A

- Ergonomic short handle with "GRIP" insert – for best accessibility
- "GRIP", soft components on the handle and thumb rest – positive handling even in extreme conditions
- Short ball joint with optimum movement radius – perfect handling
- Optimum cooling of the torch – extending torch life
- Bikox® R air cooled torches – high flexibility even at low temperatures, extremely UV resistant, considerably increased temperature resistance and tensile strength
- Time saving torch change over due to the ABICOR BINZEL central connector



MB GRIP 24 KD

Technical data (EN 60 974-7):

Rating: 250 A CO₂
220 A Mixed Gases
M21 (DIN EN 439)

Duty cycle: 60%

Wire size: 0.8 – 1.2 mm

MB GRIP 26 KD

Technical data (EN 60 974-7):

Rating: 270 A CO₂
240 A Mixed Gases
M21 (DIN EN 439)

Duty cycle: 60%

Wire size: 0.8 – 1.2 mm

MB GRIP 36 KD

Technical data (EN 60 974-7):

Rating: 320 A CO₂
290 A Mixed Gases
M21 (DIN EN 439)

Duty cycle: 60%

Wire size: 0.8 – 1.2 mm

Torch complete Type	Handle	Part-No.			Swan neck	
		3 m	4 m	5 m	Type	Part-No.
MB GRIP 24 KD	Type "MB GRIP"	012.0251	012.0252	012.0253	50°	012.0001
MB GRIP 26 KD	Type "MB GRIP"	018.0146	018.0147	018.0148	50°	018.0001
MB GRIP 36 KD	Type "MB GRIP"	014.0334	014.0335	014.0336	50°	014.0006

MB GRIP 24, MB GRIP 26, MB GRIP 36

Wear parts

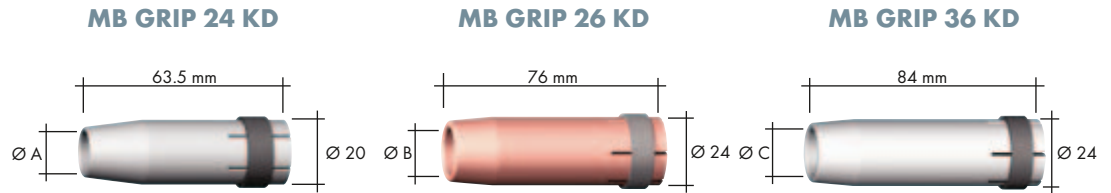

Gas nozzle (10 pcs.)

	Ø A		Ø B		Ø C	
Cylindrical	Ø 17	145.0047	Ø 20	145.0051	Ø 19	145.0045
Conical	Ø 12.5	145.0080	Ø 16	145.0085	Ø 16	145.0078
Conical	Ø 10	145.0128	Ø 14	145.0132	Ø 12	145.0126

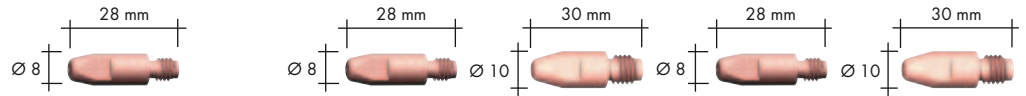

Contact tip (10 pcs.)

		M6	M6	M8	M6	M8
E-Cu	Ø 0.8	140.0051	140.0051	140.0114	140.0051	140.0114
	Ø 1.0	140.0242	140.0242	140.0313	140.0242	140.0313
	Ø 1.2	140.0379	140.0379	140.0442	140.0379	140.0442
E-Cu for Al	Ø 0.8	141.0001	141.0001	141.0003	141.0001	141.0003
	Ø 1.0	141.0006	141.0006	141.0008	141.0006	141.0008
	Ø 1.2	141.0010	141.0010	141.0015	141.0010	141.0015
CuCrZr	Ø 0.8	140.0054	140.0054	140.0117	140.0054	140.0117
	Ø 1.0	140.0245	140.0245	140.0316	140.0245	140.0316
	Ø 1.2	140.0382	140.0382	140.0445	140.0382	140.0445

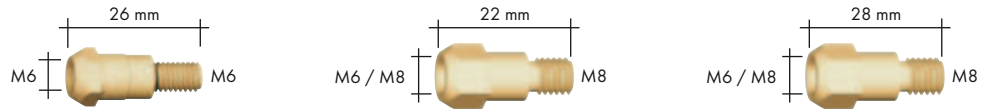

Contact tip holder (10 pcs.)

M6	142.0003	142.0007	142.0005
M8	-	142.0082	142.0020

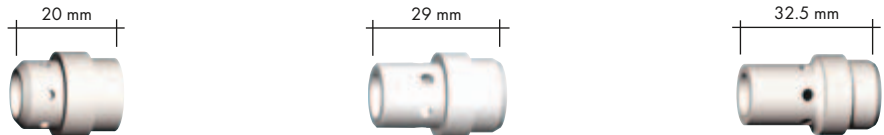

Gas diffuser (10 pcs.)

Standard	012.0183	018.0116	014.0261
Long life	-	-	014.0026
Ceramic	-	018.0141	014.0023

Liner		for 3 m	for 4 m	for 5 m
Insulated liner	Ø 0.8	124.0011	124.0012	124.0015
	Ø 1.0	124.0026	124.0031	124.0035
	Ø 1.2	124.0026	124.0031	124.0035
Carbon PTFE liner	Ø 0.8	126.0005	126.0008	126.0011
	Ø 1.0	126.0021	126.0026	126.0028
	Ø 1.2	126.0021	126.0026	126.0028
Carbon PTFE liner	Ø 0.8	127.0002	127.0003	127.0004
	Ø 1.0	127.0005	127.0007	127.0008
	Ø 1.2	127.0005	127.0007	127.0008



MIG/MAG Welding Torches "MB GRIP" liquid cooled

Rating 270 A up to 550 A

- Ergonomic short handle with "GRIP" insert – for best accessibility
- "GRIP", soft components on the handle and thumb rest – positive handling even in extreme conditions
- Ball joint with optimum movement radius – perfect handling
- Optimum cooling of the torch – extending torch life
- Time saving torch change over due to the ABICOR BINZEL central connector
- Ergonomically and technically proven and 100% reliable



MB GRIP 240 D

Technical data (EN 60 974-7):

Rating: 300 A CO₂
270 A Mixed Gases
M21 (DIN EN 439)

Duty cycle: 100%

Wire size: 0.8 – 1.2 mm

MB GRIP 401 D / MB GRIP 401

Technical data (EN 60 974-7):

Rating: 400 A / 450 A CO₂
350 A / 400 A Mixed Gases
M21 (DIN EN 439)

Duty cycle: 100%

Wire size: 0.8 – 1.2 mm

MB GRIP 501 D / MB GRIP 501

Technical data (EN 60 974-7):

Rating: 500 A / 550 A CO₂
450 A / 500 A Mixed Gases
M21 (DIN EN 439)

Duty cycle: 100%

Wire size: 1.0 – 1.6 mm

Note for liquid cooled torches:

To protect cable assembly components from excessive heat build up we recommend a post welding cooling cycle of at least four minutes.

Torch complete Type	Handle	Part-No.			Swan neck	
		3 m	4 m	5 m	Type	Part-No.
MB GRIP 240 D	Type "MB GRIP"	023.0225	023.0226	023.0227	50°	023.0228
MB GRIP 401 D	Type "MB GRIP"	033.0271	033.0272	033.0273	50°	033.0277
MB GRIP 401	Type "MB GRIP"	030.0205	030.0206	030.0207	50°	030.0208
MB GRIP 501 D	Type "MB GRIP"	034.0492	034.0493	034.0494	50°	034.0496
MB GRIP 501	Type "MB GRIP"	032.0231	032.0232	032.0233	50°	032.0234

MB GRIP 240, MB GRIP 401 / 501

Wear parts

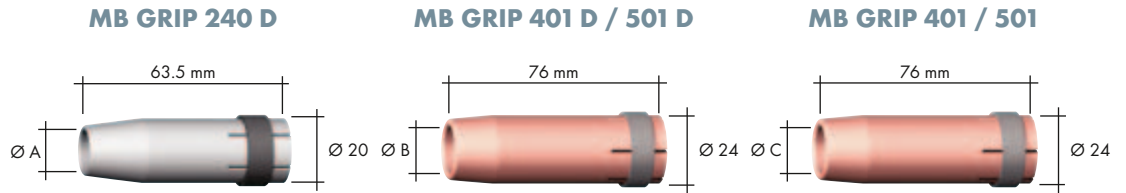

Gas nozzle (10 pcs.)

	Ø A		Ø B		Ø C	
Cylindrical	Ø 17	145.0047	Ø 20	145.0051	Ø 20	145.0051
Conical	Ø 12.5	145.0080	Ø 16	145.0085	Ø 16	145.0085
Conical	Ø 10	145.0128	Ø 14	145.0132	Ø 14	145.0132

Contact tip (10 pcs.)

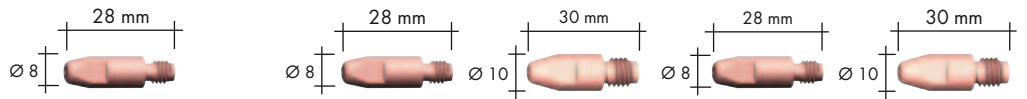

		M6	M6	M8	M6	M8
E-Cu	Ø 0.8	140.0051	140.0051	140.0114	140.0051	140.0114
	Ø 1.0	140.0242	140.0242	140.0313	140.0242	140.0313
	Ø 1.2	140.0379	140.0379	140.0442	140.0379	140.0442
	Ø 1.6	-	140.0555	140.0587	140.0555	140.0587
E-Cu for Al	Ø 0.8	141.0001	141.0001	141.0003	141.0001	141.0003
	Ø 1.0	141.0006	141.0006	141.0008	141.0006	141.0008
	Ø 1.2	141.0010	141.0010	141.0015	141.0010	141.0015
	Ø 1.6	-	141.0020	141.0022	141.0020	141.0022
CuCrZr	Ø 0.8	140.0054	140.0054	140.0117	140.0054	140.0117
	Ø 1.0	140.0245	140.0245	140.0316	140.0245	140.0316
	Ø 1.2	140.0382	140.0382	140.0445	140.0382	140.0445
	Ø 1.6	-	140.0558	140.0590	140.0558	140.0590

Contact tip holder (10 pcs.)

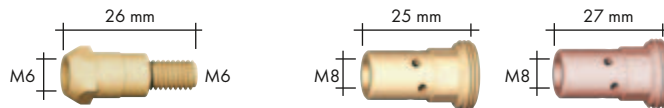

M6	142.0003	142.0008	-	-
M8	-	142.0022	142.0201.10	-

Gas diffuser (10 pcs.)

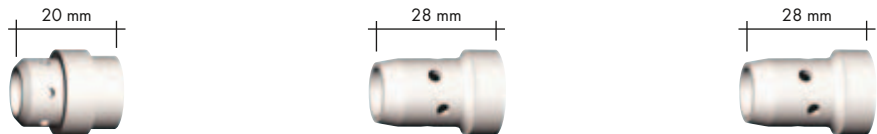

Standard	012.0183	030.0145	030.0145
Long life	-	030.0037	030.0037
Ceramic	-	030.0190	030.0190



Liner		for 3 m	for 4 m	for 5 m
Liner	Ø 0.8	122.0005	122.0007	122.0009
	Ø 1.0	122.0031	122.0036	122.0039
	Ø 1.2	122.0031	122.0036	122.0039
	Ø 1.6	122.0056	122.0060	122.0063
PTFE liner	Ø 0.8	126.0005	126.0008	126.0011
	Ø 1.0	126.0021	126.0026	126.0028
	Ø 1.2	126.0021	126.0026	126.0028
	Ø 1.6	126.0039	126.0042	126.0045
Carbon PTFE liner	Ø 0.8	127.0002	127.0003	127.0004
	Ø 1.0	127.0005	127.0007	127.0004
	Ø 1.2	127.0005	127.0007	127.0008
	Ø 1.6	127.0010	127.0012	127.0013

MIG/MAG Welding Torches "MB ERGO"

Air and liquid cooled • rating 150 A up to 550 A

The MIG/MAG torch series "MB" is available in air and liquid cooled varieties and combines progressive technology and quality, enabling trouble-free operation for every application. All torches are thoroughly designed to provide comfortable and precise operation.

- Worldwide recognized top quality
- Ergonomically and technically advanced and 100% reliable
- Optimum cooling of the torch, extending torch life
- Time saving torch change over due to the ABICOR BINZEL central adapter system



Technical data (EN 60 974-7):

MIG/MAG Welding Torches "MB ERGO" (air cooled)

Type	Rating (A)		Duty cycle (%)	Wire size (mm)
	CO ₂	Mixed Gases M21		
MB ERGO 15 AK / MB ERGO 15 AK-FX	180	150	60	0.6-1.0
MB ERGO 24 KD	250	220	35	0.8-1.2
MB ERGO 25 AK / MB ERGO 25 AK-FX	230	200	60	0.8-1.2
MB ERGO 26 KD	230	200	35	0.8-1.2
MB ERGO 36 KD	300	270	60	0.8-1.2

MIG/MAG Welding Torches "MB ERGO" (liquid cooled)

Type	Rating (A)		Duty cycle (%)	Wire size (mm)
	CO ₂	Mixed Gases M21		
MB ERGO 240 D	300	270	100	0.8-1.2
MB ERGO 401 D	400	350	100	0.8-1.2
MB ERGO 401	450	400	100	0.8-1.2
MB ERGO 501 D	500	450	100	1.0-1.6
MB ERGO 501	550	500	100	1.0-1.6

Subjected to change without notice.

"MB ERGO" Torch series



Torch complete* Type	Handle	Part-No.			Swan neck	
		3 m	4 m	5 m	Type	Part-No.
MB ERGO 15 AK	Type "MB ERGO"	002.0449	002.0450	002.0451	50°	002.0009
MB ERGO 15 AK-FX	Type "MB ERGO"	002.0455	002.0456	002.0469	flexible	002.0029
MB ERGO 24 KD	Type "MB ERGO"	012.0103	012.0104	012.0105	50°	012.0001
MB ERGO 25 AK	Type "MB ERGO"	004.0312	004.0313	004.0314	50°	004.0012
MB ERGO 25 AK-FX	Type "MB ERGO"	004.0329	004.0330	004.0331	flexible	004.0032
MB ERGO 26 KD	Type "MB ERGO"	018.0062	018.0063	018.0064	50°	018.0001
MB ERGO 36 KD	Type "MB ERGO"	014.0143	014.0144	014.0145	50°	014.0006
MB ERGO 240 D	Type "MB ERGO"	023.0077	023.0078	023.0079	50°	023.0001
MB ERGO 401 D	Type "MB ERGO"	033.0107	033.0108	033.0109	50°	033.0001
MB ERGO 401	Type "MB ERGO"	030.0125	030.0126	030.0127	50°	030.0001
MB ERGO 501 D	Type "MB ERGO"	034.0160	034.0161	034.0162	50°	034.0001
MB ERGO 501	Type "MB ERGO"	032.0145	032.0146	032.0147	50°	032.0002

* All torches are equipped including central adapter with spring pins.
Wear parts see "MB GRIP" torches of similar design (Page 4-9).

Note for liquid cooled torches:

To protect cable assembly components from excessive heat build up we recommend a post welding cooling cycle of at least four minutes.

MIG/MAG Welding Torches "ABIMIG® GRIP A"

Air cooled • rating 170 A up to 270 A

MIG/MAG Welding Torches ABIMIG® GRIP A LW air cooled with the innovative two-component handle system "GRIP", combine ergonomics and feel with all common module variations (for switch and control functions) as well as "top trigger" solutions. "GRIP" insert and ball joint in the handle guarantees secure grip and optimal handling.

The torches of the ABIMIG® GRIP A LW series utilize the newly developed Low Weight Bikox®, which gives perfect balance to the torches for effortless welding in all positions.

All torches are carefully designed to provide comfortable and precise operation.

- Low Weight Bikox® – up to 50% weight saving
- Ergonomic short handle with "GRIP" soft components on the handle, thumb rest and ball joint – guarantees optimal handling in all positions
- Screw-on gas nozzle with thermo-protective insulation – extending torch life
- Function integrated tip holder (gas diffuser, gas nozzle holder and contact tip holder in one piece) – reduces stock requirements
- Laminar gas feed – excellent gas coverage for best welding results
- Changeable gas nozzle seat – "extends" operating cycle of the torch neck and reduces maintenance costs
- Electrically insulated liner and connection nut (on the central adaptor) – enables exact setting of the arc parameters and therefore repeatability of welding results



ABIMIG® GRIP A 155 LW

Technical data (EN 60 974-7):

Rating: 240 A / 190 A CO₂
 220 A / 170 A Mixed Gases
 M21 (DIN EN 439)

Duty cycle: 35% / 60%

Wire size: 0.6 – 1.0 mm

ABIMIG® GRIP A 255 LW

Technical data (EN 60 974-7):

Rating: 270 A / 240 A CO₂
 240 A / 210 A Mixed Gases
 M21 (DIN EN 439)

Duty cycle: 35% / 60%

Wire size: 0.8 – 1.2 mm

Torch complete Type	Handle	Part-No.			Swan neck	
		3 m	4 m	5 m	Type	Part-No.
ABIMIG® GRIP A 155 LW	Type "MB GRIP"	767.D600.1	767.D601.1	767.D602.1	45°	767.D603.1
ABIMIG® GRIP A 255 LW	Type "MB GRIP"	767.D630.1	767.D631.1	767.D632.1	45°	767.D633.1

ABIMIG® GRIP A 155 LW, ABIMIG® GRIP A 255 LW

Wear parts

ABIMIG® GRIP A 155 LW

ABIMIG® GRIP A 255 LW

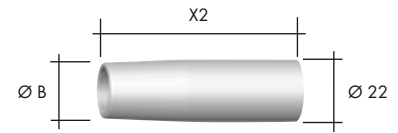
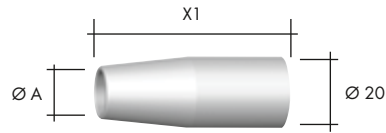

Gas nozzle (5 pcs.)

	Ø	X1		Ø B	X2	
Cylindrical	Ø 17	52 mm	145.D003	Ø 18	69 mm	145.D014
Conical	Ø 12	52 mm	145.D001	Ø 16	70 mm	145.D011
Conical	Ø 12	54 mm	145.D004	Ø 14	67 mm	145.D012

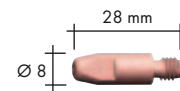
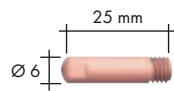

Contact tip (10 pcs.)

		M6		M6	
E-Cu	Ø 0.6	140.0008	-	-	-
	Ø 0.8	140.0059	140.0051	140.0051	140.0051
	Ø 1.0	140.0253	140.0242	140.0242	140.0242
	Ø 1.2	-	140.0379	140.0379	140.0379
E-Cu for Al	Ø 0.8	141.0002	141.0001	141.0001	141.0001
	Ø 1.0	141.0007	141.0006	141.0006	141.0006
	Ø 1.2	-	141.0010	141.0010	141.0010
CuCrZr	Ø 0.6	140.0855	-	-	-
	Ø 0.8	140.0062	140.0054	140.0054	140.0054
	Ø 1.0	140.0256	140.0245	140.0245	140.0245
	Ø 1.2	-	140.0382	140.0382	140.0382

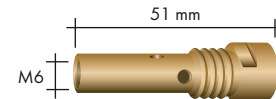
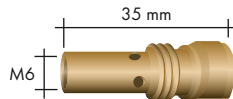

Contact tip holder (5 pcs.)

	006.D719.5	004.D624.5
--	------------	------------

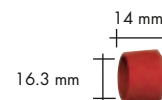
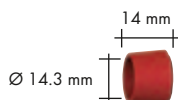

Adapter piece (5 pcs.)

	767.D607.5	767.D637.5
--	------------	------------

Liner		for 3 m		for 4 m		for 5 m	
Liner	Ø 0.6	124.0011	124.0012	124.0012	124.0015	124.0015	124.0015
	Ø 0.8	124.0011	124.0012	124.0012	124.0015	124.0015	124.0015
	Ø 1.0	124.0026	124.0031	124.0031	124.0035	124.0035	124.0035
	Ø 1.2	124.0026	124.0031	124.0031	124.0035	124.0035	124.0035
PTFE liner	Ø 0.6	126.0005	126.0008	126.0008	126.0011	126.0011	126.0011
	Ø 0.8	126.0005	126.0008	126.0008	126.0011	126.0011	126.0011
	Ø 1.0	126.0021	126.0026	126.0026	126.0028	126.0028	126.0028
	Ø 1.2	126.0021	126.0026	126.0026	126.0028	126.0028	126.0028
Carbon PTFE liner	Ø 0.6	127.0002	127.0003	127.0003	127.0004	127.0004	127.0004
	Ø 0.8	127.0002	127.0003	127.0003	127.0004	127.0004	127.0004
	Ø 1.0	127.0005	127.0007	127.0007	127.0008	127.0008	127.0008
	Ø 1.2	127.0005	127.0007	127.0007	127.0008	127.0008	127.0008

MIG/MAG Welding Torches "ABIMIG® GRIP A LW"

Air cooled • rating 240 A up to 430 A

- Low Weight Bikox® – up to 50% weight saving
- Ergonomic short handle with "GRIP" soft components on the handle, thumb rest and ball joint – guarantees optimal handling in all positions
- Screw-on gas nozzle with thermo-protective insulation – extending torch life
- Function integrated tip holder (gas diffuser, gas nozzle holder and contact tip holder in one piece) – reduces stock requirements
- Laminar gas feed – excellent gas coverage for best welding results
- Changeable gas nozzle seat – "extends" operating cycle of the torch neck and reduces maintenance costs
- Electrically insulated liner and connection nut (on the central adaptor) – enables exact setting of the arc parameters and therefore repeatability of welding results

Additionally for ABIMIG® GRIP A 405 LW:

- Bikox® with large flow cross-section – guarantees gas coverage
- Specially designed steel liner – guarantees optimum and consistent wire feeding



ABIMIG® GRIP A 305 LW

Technical data (EN 60 974-7):

Rating: 315 A / 270 A CO₂
300 A / 240 A Mixed Gases
M21 (DIN EN 439)

Duty cycle: 35% / 60%

Wire size: 0.8 – 1.2 mm

ABIMIG® GRIP A 355 LW

Technical data (EN 60 974-7):

Rating: 350 A / 300 A CO₂
320 A / 270 A Mixed Gases
M21 (DIN EN 439)

Duty cycle: 35% / 60%

Wire size: 1.0 – 1.6 mm

ABIMIG® GRIP A 405 LW

Technical data (EN 60 974-7):

Rating: 430 A / 370 A CO₂
350 A / 300 A Mixed Gases
M21 (DIN EN 439)

Duty cycle: 35% / 60%

Wire size: 1.0 – 1.6 mm

Torch complete Type	Handle	Part-No.			Swan neck	
		3 m	4 m	5 m	Type	Part-No.
ABIMIG® GRIP A 305 LW	Type "MB GRIP"	767.D660.1	767.D661.1	767.D662.1	45°	767.D663.1
ABIMIG® GRIP A 355 LW	Type "MB GRIP"	767.D690.1	767.D691.1	767.D692.1	45°	767.D693.1
ABIMIG® GRIP A 405 LW	Type "ABIMIG® GRIP"	767.D720.1	767.D721.1	767.D722.1	45°	767.D723.1

ABIMIG® GRIP A 305 LW, ABIMIG® GRIP A 355 LW, ABIMIG® GRIP A 405 LW

Wear parts

ABIMIG® GRIP A 305 LW ABIMIG® GRIP A 355 LW

ABIMIG® GRIP A 405 LW

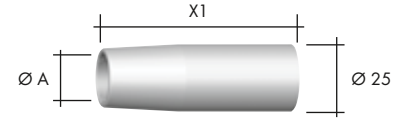
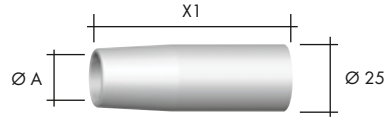

Gas nozzle (5 pcs.)

	Ø A	X1		Ø A	X1	
Cylindrical	Ø 21	71 mm	145.D024	Ø 21	71 mm	145.D024
Conical	Ø 18	72 mm	145.D021	Ø 18	72 mm	145.D021
Conical	Ø 16	69 mm	145.D022	Ø 16	69 mm	145.D022

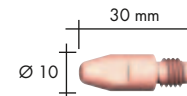
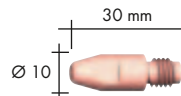

Contact tip (10 pcs.)

		M8	M8
E-Cu	Ø 0.8	140.0114	-
	Ø 1.0	140.0313	140.0313
	Ø 1.2	140.0442	140.0442
	Ø 1.6	140.0587	140.0587
E-Cu for Al	Ø 0.8	141.0003	141.0003
	Ø 1.0	141.0008	141.0008
	Ø 1.2	141.0015	141.0015
	Ø 1.6	141.0022	141.0022
CuCrZr	Ø 0.8	140.0117	140.0117
	Ø 1.0	140.0316	140.0316
	Ø 1.2	140.0445	140.0445
	Ø 1.6	140.0590	140.0590

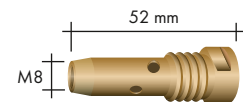
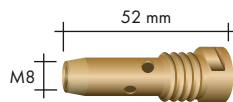

Contact tip holder (5 pcs.)

M8	014.D745.5	014.D745.5

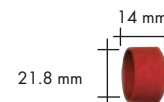
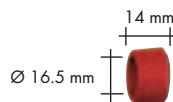

Adapter piece (5 pcs.)

	767.D668.5	767.D729.5



		305 / 355 for 3 m	405 for 3 m	305 / 355 for 4 m	405 for 4 m	305 / 355 for 5 m	405 for 5 m
Liner	0.8	124.0011	-	124.0012	-	124.0015	-
	1.0	124.0026	124.D113	124.0031	124.D114	124.0035	124.D115
	1.2	124.0026	124.D116	124.0031	124.D117	124.0035	124.D118
	1.6	124.0041	124.D119	124.0042	124.D120	124.0044	124.D121
PTFE liner	0.8	126.0005	-	126.0008	-	126.0011	-
	1.0	126.0021	-	126.0026	-	126.0028	-
	1.2	126.0021	-	126.0026	-	126.0028	-
	1.6	126.0039	-	126.0042	-	126.0045	-
Carbon PTFE liner	0.8	127.0002	-	127.0003	-	127.0004	-
	1.0	127.0005	-	127.0007	-	127.0008	-
	1.2	127.0005	-	127.0007	-	127.0008	-
	1.6	127.0010	-	127.0012	-	127.0013	-

Note: Combined wire guides for ABIMIG® A / A T 405 LW on page 33.

MIG/MAG Welding Torches "ABIMIG® A T LW"

Air cooled • rating 180 A up to 240 A

The newly developed, super lightweight MIG/MAG welding torch series "ABIMIG® A T LW" with ergonomic and universal two-component handle offer flexibility in perfection. They are equipped standard with ball joint and lightweight "Bikox® LW" cable assembly as well as exchangeable and 360° rotatable torch neck, so the torches enable ergonomic and relaxed welding in every position.

- New welding torch series and lightweight "Bikox® LW" cable assembly – Reduction of the torch weight up to 50 %
- Newly designed ergonomic handle, optionally available with Up/Down module – Improved working comfort
- Universal contact tip holder (contact tip holder, gas diffuser and gas nozzle holder all in one) – Reduction of the number of spare parts and thus the costs
- Screwable, thermally insulated gas nozzle – Longer service life of the torch and cost reduction
- Turnable, quick-change torch neck – increased working comfort and reduction of service costs

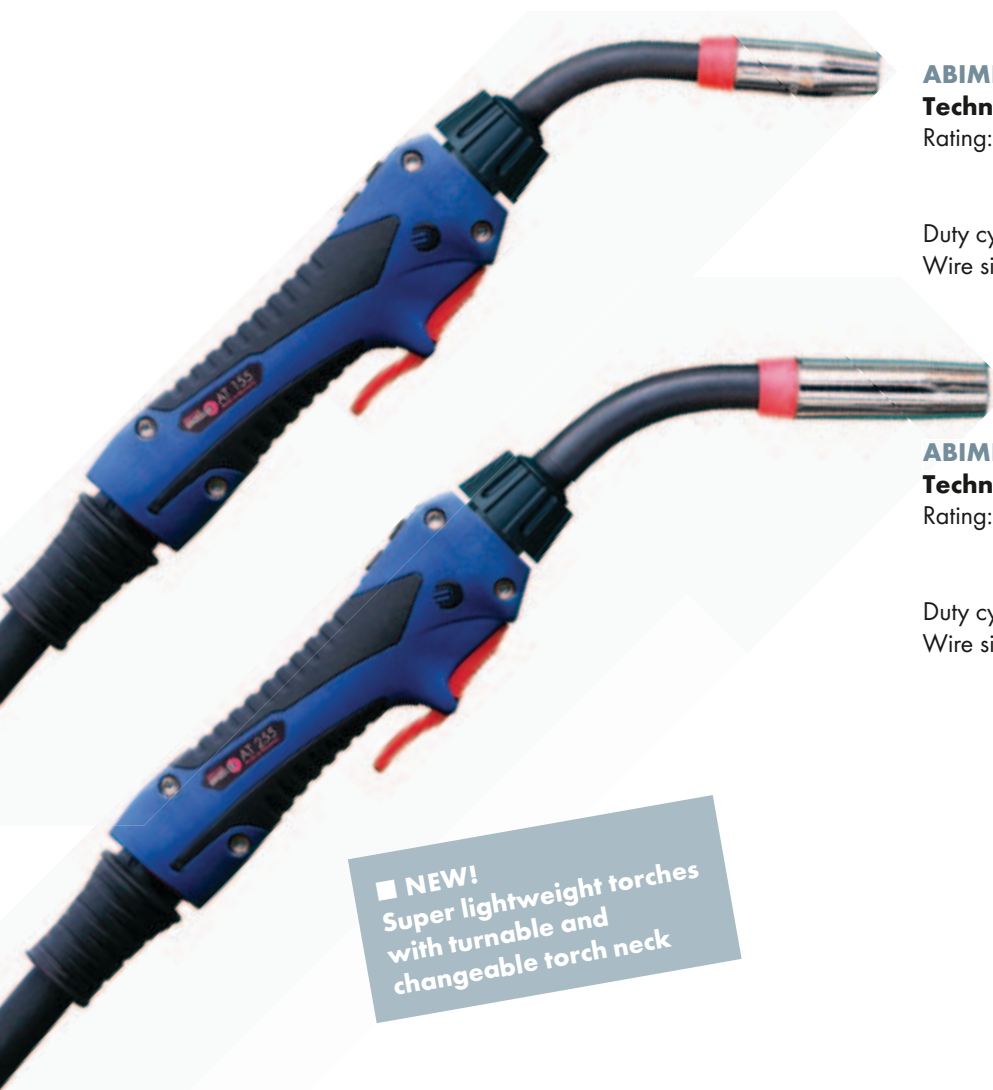

ABIMIG® A T 155 LW

Technical data (EN 60 974-7):

Rating: 190 A CO₂
180 A Mixed Gases
M21 (DIN EN 439)

Duty cycle: 60%

Wire size: 0.8–1.0 mm

ABIMIG® A T 255 LW

Technical data (EN 60 974-7):

Rating: 240 A CO₂
220 A Mixed Gases
M21 (DIN EN 439)

Duty cycle: 60%

Wire size: 0.8–1.2 mm

■ **NEW!**
Super lightweight torches
with turnable and
changeable torch neck

Torch complete Type	Handle	Part-No.			Swan neck	
		3 m	4 m	5 m	Type	Part-No.
ABIMIG® A T 155 LW	Push-button long	006.D810.1	006.D811.1	006.D812.1	45°	006.D804.1
ABIMIG® A T 255 LW	Push-button long	004.D850.1	004.D851.1	004.D852.1	45°	004.D831.1

Definition: T = turnable/exchangeable torch neck, LW = lightweight cable assembly

Attention: The specified variants correspond to the "BASIC" version. Further versions (COMBI, VARIO, FREE STYLE) on request.

ABIMIG® A T 155 LW, ABIMIG® A T 255 LW

Wear parts

ABIMIG® A T 155 LW

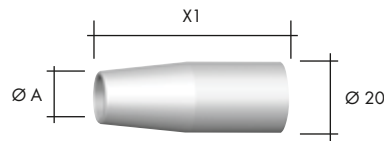

ABIMIG® A T 255 LW

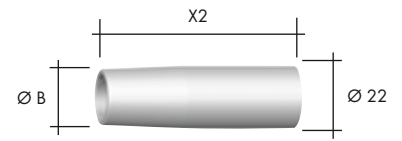

Gas nozzle (5 pcs.)

	Ø A	X1		Ø B	X2	
Cylindrical	Ø 17	52 mm	145.D003	Ø 18	69 mm	145.D014
Conical	Ø 12	52 mm	145.D001	Ø 16	70 mm	145.D011
Conical	Ø 12	54 mm	145.D004	Ø 14	67 mm	145.D012

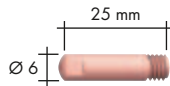

M6

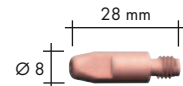

M6

Contact tip (10 pcs.)

E-Cu	Ø 0.8	140.0059	140.0051
	Ø 1.0	140.0253	140.0242
	Ø 1.2	-	140.0379
E-Cu for Al	Ø 0.8	141.0002	141.0001
	Ø 1.0	141.0007	141.0006
	Ø 1.2	-	141.0010
CuCrZr	Ø 0.8	140.0062	140.0054
	Ø 1.0	140.0256	140.0245
	Ø 1.2	-	140.0382

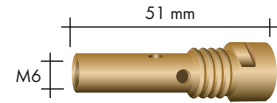
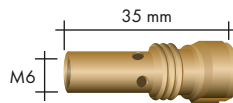

Contact tip holder (5 pcs.)

	006.D719.5	004.D624.5
--	------------	------------

Adapter piece (5 pcs.)

	767.D607.5	767.D637.5
--	------------	------------

Torch neck liner for T-torches

Standard	Ø 0.8	122.D037	122.D037
	Ø 1.0	122.D038	122.D038
	Ø 1.2	-	122.D038
Brass for Al	Ø 0.8	122.D040	122.D040
	Ø 1.0	122.D040	122.D041
	Ø 1.2	-	122.D041

Liner		for 3 m	for 4 m	for 5 m
Liner	Ø 0.8	124.0011	124.0012	124.0015
	Ø 1.0	124.0026	124.0031	124.0035
	Ø 1.2	124.0026	124.0031	124.0035
PTFE liner	Ø 0.8	126.0005	126.0008	126.0011
	Ø 1.0	126.0021	126.0026	126.0028
	Ø 1.2	126.0021	126.0026	126.0028
Carbon	Ø 0.8	127.0002	127.0003	127.0004
	Ø 1.0	127.0005	127.0007	127.0008
PTFE liner	Ø 1.0	127.0005	127.0007	127.0008
	Ø 1.2	127.0005	127.0007	127.0008



MIG/MAG Welding Torches "ABIMIG® A T LW"

Air cooled • rating 260 A up to 400 A

- New welding torch series and lightweight "Bikox® LW" cable assembly - Up to 50% lighter than comparable standard torches
- Newly designed ergonomic torch handle, available with optional Up/Down module - Improved working comfort
- Universal contact tip holder (contact tip holder, gas diffuser and gas nozzle holder all in one) - Reduces stocking requirements and costs
- Screwable, thermally insulated gas nozzle - Longer service life of the torch - Cost reduction
- Turnable, quick-change torch neck - increased working comfort and reduction of service costs



■ **NEW!**
Super lightweight torches
with turnable and
changeable torch neck

ABIMIG® A T 305 LW

Technical data (EN 60 974-7):

Rating: 290 A CO₂
260 A Mixed Gases
M21 (DIN EN 439)

Duty cycle: 60%

Wire size: 0.8-1.2 mm

ABIMIG® A T 355 LW

Technical data (EN 60 974-7):

Rating: 340 A CO₂
320 A Mixed Gases
M21 (DIN EN 439)

Duty cycle: 60%

Wire size: 1.0-1.6 mm

ABIMIG® A T 405 LW*

Technical data (EN 60 974-7):

Rating: 400 A CO₂
370 A Mixed Gases
M21 (DIN EN 439)

Duty cycle: 60%

Wire size: 1.0-1.6 mm
(up to 2.4 mm on demand)

Torch complete Type	Handle	3 m	Part-No.			Swan neck	
			4 m	5 m	Type	Part-No.	
ABIMIG® A T 305 LW	Push-button long	018.D960.1	018.D961.1	018.D962.1	45°	014.H356.1	
ABIMIG® A T 355 LW	Push-button long	014.H390.1	014.H391.1	014.H392.1	45°	014.H363.1	
ABIMIG® A T 405 LW	Push-button long	015.D070.1	015.D071.1	015.D072.1	45°	015.D082.1	

Definition: T = turnable/exchangeable torch neck, LW = lightweight cable assembly

Attention: The specified variants correspond to the "BASIC" version. Further versions (COMBI, VARIO, FREE STYLE) on request.

*The ABIMIG® A T 405 LW is adjustable in 45° steps.

ABIMIG® A T 305 LW, ABIMIG® A T 355 LW, ABIMIG® A T 405 LW

Wear parts

ABIMIG® A T 305 / 355 LW

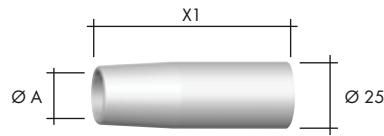

ABIMIG® A T 405 LW

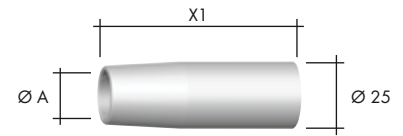

Gas nozzle (5 pcs.)

	Ø A	X1		Ø A	X1	
Cylindrical	Ø 21	71 mm	145.D024	Ø 21	71 mm	145.D024
Conical	Ø 18	72 mm	145.D021	Ø 18	72 mm	145.D021
Conical	Ø 16	69 mm	145.D022	Ø 16	69 mm	145.D022

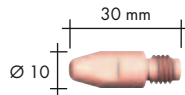

M8

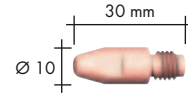

M8

Contact tip (10 pcs.)

E-Cu	Ø 0.8	140.0114	140.0114
	Ø 1.0	140.0313	140.0313
	Ø 1.2	140.0442	140.0442
	Ø 1.6	140.0587	140.0587
E-Cu for Al	Ø 0.8	141.0003	141.0003
	Ø 1.0	141.0008	141.0008
	Ø 1.2	141.0015	141.0015
	Ø 1.6	141.0022	141.0022
CuCrZr	Ø 0.8	140.0117	140.0117
	Ø 1.0	140.0316	140.0316
	Ø 1.2	140.0445	140.0445
	Ø 1.6	140.0590	140.0590

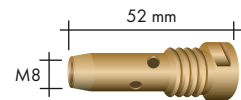
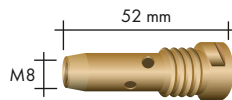

Contact tip holder (5 pcs.)

M8	014.D745.5	014.D745.5
----	------------	------------



Adapter piece (5 pcs.)

	767.D668.5	015.D080.5
--	------------	------------

Torch neck liner for T-torches



Standard	Ø 0.8	122.D037	-
	Ø 1.0-1.2	122.D038	122.D077
	Ø 1.6	122.D045	122.D078
Brass for Al	Ø 1.0	122.D040	122.D040
	Ø 1.0-1.2	122.D041	122.D041

Liner	Ø	305 / 355	405	305 / 355	405	305 / 355	405
		for 3 m	for 3 m	for 4 m	for 4 m	for 5 m	for 5 m
Liner	0.8	124.0011	-	124.0012	-	124.0015	-
	1.0	124.0026	124.D113	124.0031	124.D114	124.0035	124.D115
	1.2	124.0026	124.D116	124.0031	124.D117	124.0035	124.D118
	1.6	124.0041	124.D119	124.0042	124.D120	124.0044	124.D121
PTFE liner	0.8	126.0005	-	126.0008	-	126.0011	-
	1.0	126.0021	-	126.0026	-	126.0028	-
	1.2	126.0021	-	126.0026	-	126.0028	-
	1.6	126.0039	-	126.0042	-	126.0045	-
Carbon PTFE liner	0.8	127.0002	-	127.0003	-	127.0004	-
	1.0	127.0005	-	127.0007	-	127.0008	-
	1.2	127.0005	-	127.0007	-	127.0008	-
	1.6	127.0010	-	127.0012	-	127.0013	-

Note: Combined wire guides for ABIMIG® A / A T 405 LW on page 33.

MIG/MAG Welding Torches "ABIMIG® GRIP W"

Liquid cooled • rating 400 A up to 575 A

MIG/MAG welding torches ABIMIG® GRIP W liquid cooled with the innovative two-component handle system "GRIP" combine ergonomics and feel with all common module variations (for switch and control functions) as well as "top trigger" solutions. "GRIP" insert and ball joint in the handle guarantees secure grip and optimal handling.

The liquid cooled ABIMIG® GRIP W torches particularly excel in pulse arc welding due to an optimized dual-circuit cooling system that ensures "extra-cool" wear parts and therefore extended service life.

All torches are thoroughly designed to provide comfortable and precise operation.

- Dual-circuit cooling system with increased cooling liquid flow and novel heat dissipation for optimum power and heat conduction – guarantees less spatter adhesion and therefore extremely extended service life of wear and spare parts
- Additional torch neck protection through a UV, ozone and temperature resistant protective cover – for longer torch service life
- The newly developed torch neck and handle system ABIMIG® GRIP with ball joint guarantees optimum balance – even for welding tasks when access is difficult
- Except the tip holder, all spare and wear parts of the ABIMIG® GRIP W 555 series are compatible with the torch series MB 401/501 – reduced stocking requirements
- Mechanically resilient and robust tip holder (optionally soldered or changeable) – long service life

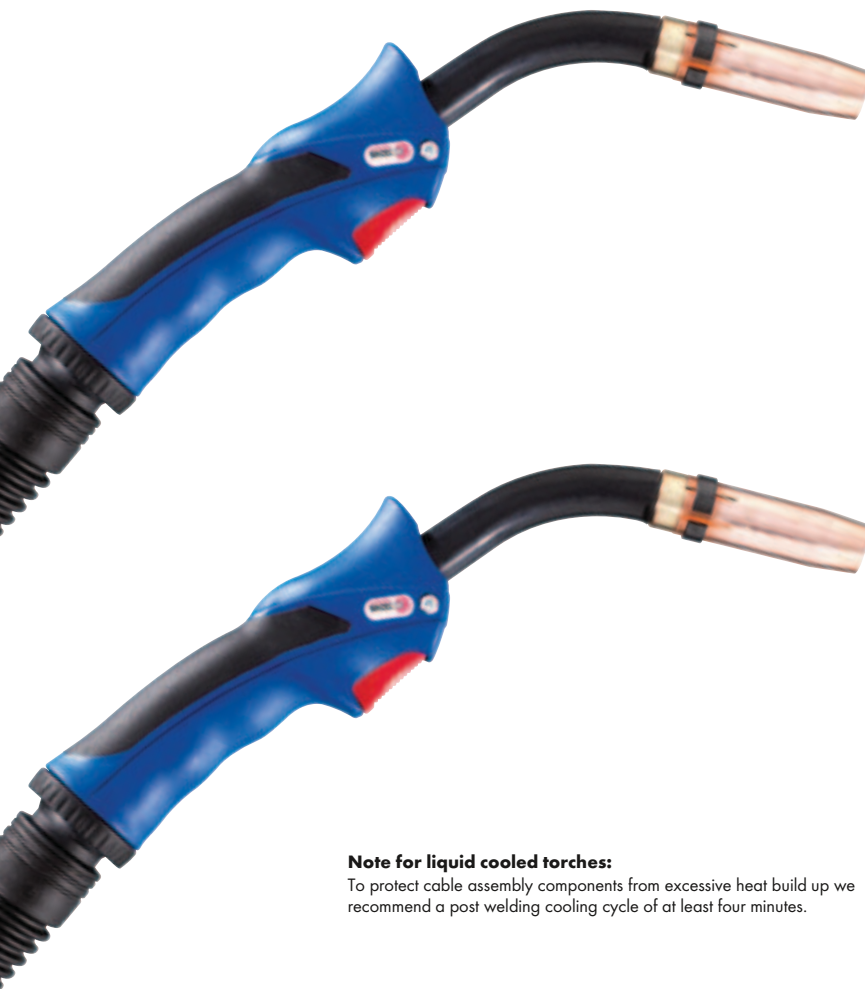

ABIMIG® GRIP W 555 D / ABIMIG® GRIP W 555 D TS

Technical data (EN 60 974-7):

Rating:	550 A CO ₂ 500 A Mixed Gases 400 A Pulse M21 (DIN EN 439)
Duty cycle:	100%
Wire size:	0.8 – 1.6 mm

ABIMIG® GRIP W 555

Technical data (EN 60 974-7):

Rating:	575 A CO ₂ 525 A Mixed Gases 400 A Pulse M21 (DIN EN 439)
Duty cycle:	100%
Wire size:	0.8 – 1.6 mm

Note for liquid cooled torches:

To protect cable assembly components from excessive heat build up we recommend a post welding cooling cycle of at least four minutes.

Torch complete Type	Handle	3 m	Part-No.			Swan neck	
			4 m	5 m	Type	Part-No.	
ABIMIG® GRIP W 555 D	Type "ABIMIG® GRIP"	766.0526.1	766.0527.1	766.0528.1	50°	766.0532.1	
ABIMIG® GRIP W 555 D TS	Type "ABIMIG® GRIP"	766.1457.1	766.1458.1	766.1459.1	50°	766.0900.1	
ABIMIG® GRIP W 555	Type "ABIMIG® GRIP"	766.0529.1	766.0530.1	766.0531.1	50°	766.0533.1	

ABIMIG® GRIP W 555 D, ABIMIG® GRIP W 555, ABIMIG® GRIP W 555 D TS

Wear parts



Gas nozzle

	Ø A		Ø A		Ø A	
Cylindrical	Ø 20	145.0051	Ø 20	145.0709.5	Ø 20	145.0051
Conical	Ø 16	145.0085	Ø 16	145.0708.5	Ø 16	145.0085
Conical	Ø 14	145.0132	Ø 14	-	Ø 14	145.0132

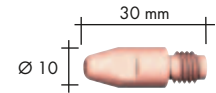
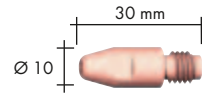
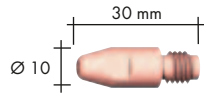

Contact tip (10 pcs.)

		M8	M8	M8
E-Cu	Ø 0.8	140.0114	140.0114	140.0114
	Ø 1.0	140.0313	140.0313	140.0313
	Ø 1.2	140.0442	140.0442	140.0442
	Ø 1.6	140.0587	140.0587	140.0587
E-Cu for Al	Ø 0.8	141.0003	141.0003	141.0003
	Ø 1.0	141.0008	141.0008	141.0008
	Ø 1.2	141.0015	141.0015	141.0015
	Ø 1.6	141.0022	141.0022	141.0022
CuCrZr	Ø 0.8	140.0117	140.0117	140.0117
	Ø 1.0	140.0316	140.0316	140.0316
	Ø 1.2	140.0445	140.0445	140.0445
	Ø 1.6	140.0590	140.0590	140.0590

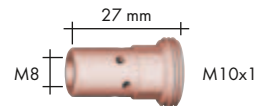
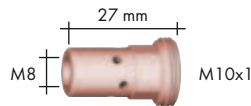

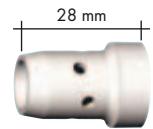
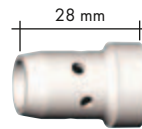
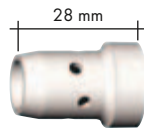

Contact tip holder (10 pcs.)

M8	142.0201.10	142.0201.10	-
----	-------------	-------------	---



Gas diffuser (10 pcs.)

Standard	030.0145	030.0145	030.0145
Long life	030.0037	030.0037	030.0037
Ceramic	030.0190	030.0190	030.0190

	Liner	for 3 m	for 4 m	for 5 m	
	Liner	Ø 0.8	124.0137	124.0138	124.0139
		Ø 1.0	124.0111	124.0112	124.0113
		Ø 1.2	124.0111	124.0112	124.0113
		Ø 1.6	124.0114	124.0115	124.0116
	PTFE liner	Ø 0.8	126.0005	126.0008	126.0011
		Ø 1.0	126.0021	126.0026	126.0028
		Ø 1.2	126.0021	126.0026	126.0028
		Ø 1.6	126.0039	126.0042	126.0045
Carbon	PTFE liner	Ø 0.8	127.0002	127.0003	127.0004
		Ø 1.0	127.0005	127.0007	127.0008
		Ø 1.2	127.0005	127.0007	127.0008
		Ø 1.6	127.0010	127.0012	127.0013

MIG/MAG Welding Torches "ABIMIG® GRIP W"

Liquid cooled • rating 450 A up to 625 A

- Dual-circuit cooling system with increased cooling liquid flow and new heat dissipation for optimal power and heat conduction – guarantees less spatter adhesion and therefore extremely extended service life of wear and spare parts
- Additional torch neck protection through a UV, ozone and temperature resistant protective cover – for longer torch service life
- The newly developed torch neck and handle system ABIMIG® GRIP with ball joint guarantees optimal balance – even for welding tasks when access is difficult
- Specially designed spare and wear parts for the high-performance application range – excellent results especially in pulse arc welding
- Gas nozzle with innovative "plug-screw connection" – optimal fixing and heat dissipation
- Swan neck can be delivered in three versions – with soldered or changeable tip holder M10 as well as with collet body version for push-fit "click" contact tip

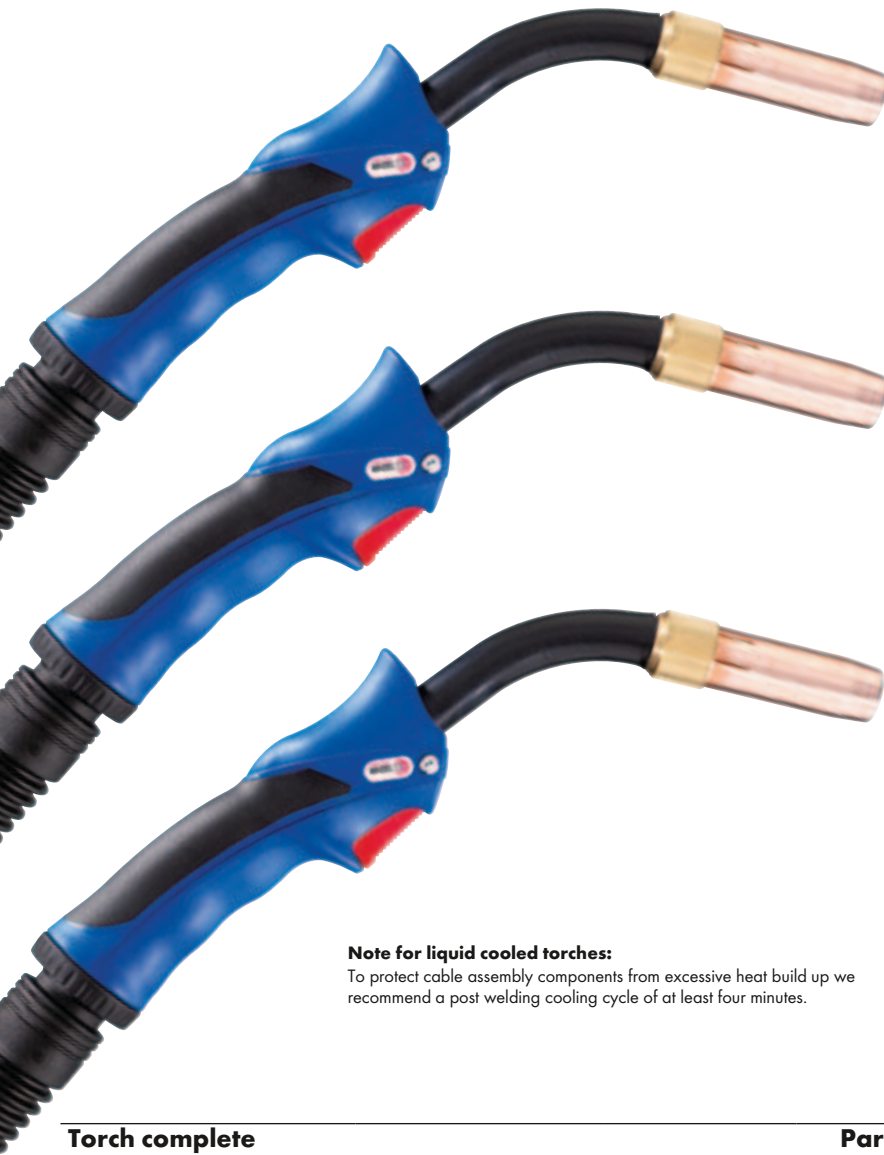

ABIMIG® GRIP W 605

Technical data (EN 60 974-7):

Rating:	625 A CO ₂ 575 A Mixed Gases 450 A Pulse M21 (DIN EN 439)
Duty cycle:	100%
Wire size:	1.0 – 1.6 mm

ABIMIG® GRIP W 605 D

Technical data (EN 60 974-7):

Rating:	600 A CO ₂ 550 A Mixed Gases 450 A Pulse M21 (DIN EN 439)
Duty cycle:	100%
Wire size:	1.0 – 1.6 mm

ABIMIG® GRIP W 605 C

Technical data (EN 60 974-7):

Rating:	600 A CO ₂ 550 A Mixed Gases 450 A Pulse M21 (DIN EN 439)
Duty cycle:	100%
Wire size:	1.0 – 1.6 mm

Note for liquid cooled torches:

To protect cable assembly components from excessive heat build up we recommend a post welding cooling cycle of at least four minutes.

Torch complete Type	Handle	Part-No.			Swan neck	
		3 m	4 m	5 m	Type	Part-No.
ABIMIG® GRIP W 605	Type "ABIMIG® GRIP"	766.0537.1	766.0538.1	766.0539.1	50°	766.0541.1
ABIMIG® GRIP W 605 D	Type "ABIMIG® GRIP"	766.0534.1	766.0535.1	766.0536.1	50°	766.0540.1
ABIMIG® GRIP W 605 C	Type "ABIMIG® GRIP"	766.0543.1	766.0544.1	766.0545.1	50°	766.0542.1

ABIMIG® GRIP W 605, ABIMIG® GRIP W 605 D, ABIMIG® GRIP W 605 C

Wear parts

ABIMIG® GRIP W 605

ABIMIG® GRIP W 605 D

ABIMIG® GRIP W 605 C

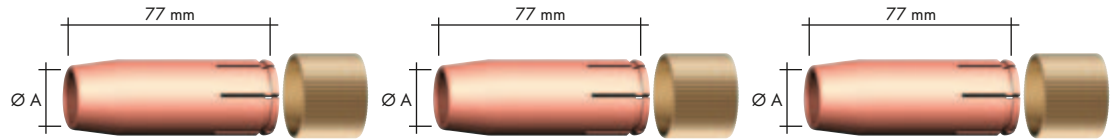

Gas nozzle (10 pcs.)		Ø A		Ø A		Ø A	
Cylindrical	Ø 20	145.0678.10	Ø 20	145.0678.10	Ø 20	145.0678.10	
Conical	Ø 17	145.0669	Ø 17	145.0669	Ø 17	145.0669	
Gas nozzle adapter		766.1070		766.1070		766.1070	

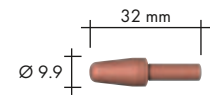
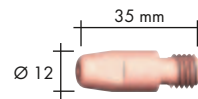
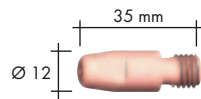

Contact tip (10 pcs.)		M10		M10			
E-Cu	Ø 1.0	140.1542.10	140.1542.10	-			
	Ø 1.2	140.1543.10	140.1543.10	-			
	Ø 1.6	140.1544.10	140.1544.10	-			
CuCrZr	Ø 1.0	140.0348	140.0348	140.1318			
	Ø 1.2	140.0481	140.0481	140.1319			
	Ø 1.6	140.0616	140.0616	140.1321			

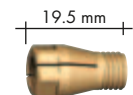
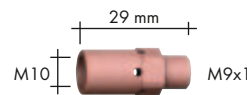

Contact tip holder / Collet body (10 pcs.)					
Contact tip holder M10		-	142.0202.10	-	
Collet body		-	-	766.1051	

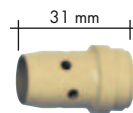
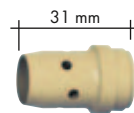
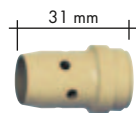

Gas diffuser (10 pcs.)					
Long Life (Standard)		766.0518	766.0518	766.0518	



Liner		for 3 m	for 4 m	for 5 m	
Liner	Ø 1.0	124.0111	124.0112	124.0113	
	Ø 1.2	124.0111	124.0112	124.0113	
	Ø 1.6	124.0114	124.0115	124.0116	
PTFE liner	Ø 1.0	126.0021	126.0026	126.0028	
	Ø 1.2	126.0021	126.0026	126.0028	
	Ø 1.6	126.0039	126.0042	126.0045	
Carbon	Ø 1.0	127.0005	127.0007	127.0008	
	PTFE liner	Ø 1.2	127.0005	127.0007	127.0008
		Ø 1.6	127.0010	127.0012	127.0013

MIG/MAG Welding Torches Push-Pull Plus

Air and liquid cooled



Note for liquid cooled torches:

To protect cable assembly components from excessive heat build up we recommend a post welding cooling cycle of at least four minutes.



The screw-type torch necks can be replaced quickly. They are available as either straight or 45° angled versions. A special interface between the handle and the torch neck makes it possible to turn the necks up to 360°. All torches, both air and liquid-cooled for capacities of up to 400 A, are based on the tried-and-trusted "MB" torch neck design.

The main areas of application for these welding torches include wharfs, manufacturers of containers and ships etc., as well as in vehicle and wagon building. Wherever exact and constant wire feeding is an absolute must.

The welding torches of the Push-Pull Plus series, specially developed for aluminum welding requirements and the use of thin wires, makes problem-free and consistent wire feed and constant wire feed possible, even with longer cable assemblies. A powerful, sturdy pull motor with potentiometer guarantees exact speed regulation. For an optimum wire feed without frictional loss, the contact pressure of the feeding rollers can be regulated precisely and easily directly on the handle. The ergonomic handle ensures optimum, low-fatigue handling.

- Identical motor characteristics as standard Push-Pull
- Consistent and problem-free wire feeding thanks to a powerful pull motor
- Precise contact pressure regulation of the wire feeding rollers directly on the torch
- Available with optional potentiometer for speed regulation
- Wearing parts are identical to those of the tried-and-trusted MB torch series – minimised stocking
- Optimum torch cooling – long tool lives
- Sturdy design – long service life

Type	Cooling	Rating		Duty cycle (%)	Wire size (mm)
		CO ₂	Mixed Gases M21		
Push-Pull Plus 36 D	air	300 A	270 A	60	0.8-1.2
Push-Pull Plus 240 D	liquid	270 A	240 A	100	0.8-1.2
Push-Pull Plus 401 D	liquid	400 A	350 A	100	0.8-1.2

Type	Torch complete (40 V motor)		
	Part-No. 8 m without Poti	Part-No. 8 m with Poti	Part-No. Swan neck
Push-Pull Plus 36 D; straight; GZ-2	085.0104.1	085.0106.1	085.0116.1
Push-Pull Plus 36 D; 45° bend; GZ-2	085.0105.1	085.0107.1	085.0117.1
Push-Pull Plus 240 D; straight; WZ-2	095.0110.1	095.0119.1	095.0040.1
Push-Pull Plus 240 D; 45° bend; WZ-2	095.0111.1	095.0120.1	095.0052.1
Push-Pull Plus 401 D; straight; WZ-2	095.0100.1	095.0114.1	095.0002
Push-Pull Plus 401 D; 45° bend; WZ-2	095.0101.1	095.0115.1	095.0015

Wire feeding roll	Ø 0.8	Ø 1.0	Ø 1.2
ST/AL	095.0064.1	095.0065.1	095.0066.1

Push-Pull Plus 36, Push-Pull Plus 240, Push-Pull Plus 401

Wear parts

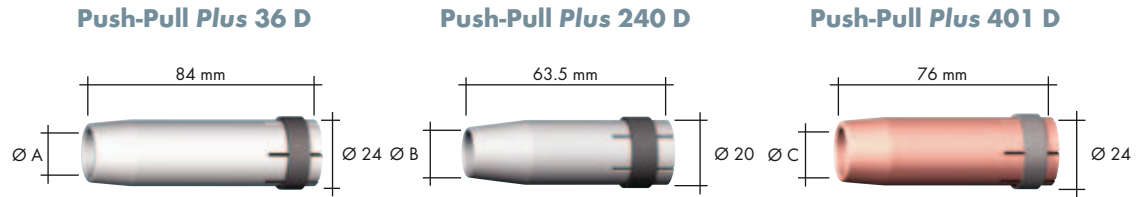

Gas nozzle (10 pcs.)

	Ø A		Ø B		Ø C	
Cylindrical	Ø 19	145.0045	Ø 17	145.0047	Ø 20	145.0051
Conical	Ø 16	145.0078	Ø 12.5	145.0080	Ø 16	145.0085
Conical	Ø 12	145.0126	Ø 10	145.0128	Ø 14	145.0132

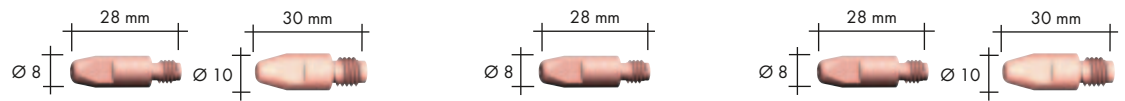

Contact tip (10 pcs.)

		M6	M8	M6	M6	M8
E-Cu	Ø 0.8	140.0051	140.0114	140.0051	140.0051	140.0114
	Ø 1.0	140.0242	140.0313	140.0242	140.0242	140.0313
	Ø 1.2	140.0379	140.0442	140.0379	140.0379	140.0442
E-Cu for Al	Ø 0.8	141.0001	141.0003	141.0001	141.0001	141.0003
	Ø 1.0	141.0006	141.0008	141.0006	141.0006	141.0008
	Ø 1.2	141.0010	141.0015	141.0010	141.0010	141.0015
CuCrZr	Ø 0.8	140.0054	140.0117	140.0054	140.0054	140.0117
	Ø 1.0	140.0245	140.0316	140.0245	140.0245	140.0316
	Ø 1.2	140.0382	140.0445	140.0382	140.0382	140.0445

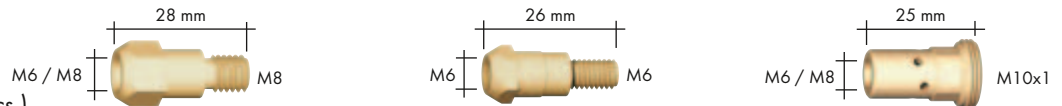

Contact tip holder (10 pcs.)

M6	142.0005	142.0003	142.0008
M8	142.0020	-	142.0022

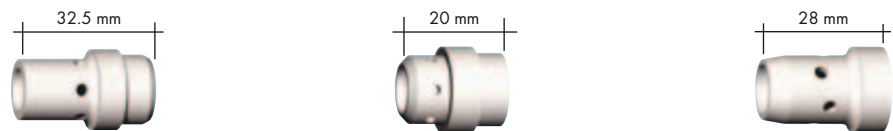

Gas diffuser (10 pcs.)

Standard	014.0261	012.0183	030.0145
Long life	014.0026	-	030.0037
Ceramic	014.0023	-	030.0190

Liner

Neck liner ¹ 0.8-1.0 mm	149.0260.3	149.0264.3	149.0264.3
Neck liner ¹ 1.2 mm	149.0261.3	149.0265.3	149.0265.3
Neck liner ² 0.8-1.0 mm	149.0262.3	149.0266.3	149.0266.3
Neck liner ² 1.2 mm	149.0263.3	149.0267.3	149.0267.3
Liner blank 0.8 mm	122.0010	122.0010	122.0010
Liner blank 1.0-1.2 mm	122.0040	122.0040	122.0040
Liner insulated 0.8 mm	124.0169	124.0169	124.0169
PTFE liner 0.8 mm	126.0013	126.0013	126.0013
PTFE liner 1.0-1.2 mm	126.0030	126.0030	126.0030
Carb. PTFE liner 0.8 mm	127.0015	127.0015	127.0015
Carb. PTFE l. 1.0-1.2 mm	127.0009	127.0009	127.0009
PA liner 1.0-1.2 mm	128.0019	128.0019	128.0019

¹ For straight torch necks (0°).

² For bended torch necks (45°).

MIG/MAG Fume Extraction Torches "RAB GRIP"

Air and liquid cooled

Every welding job generates fumes and smoke that could be hazardous if inhaled. Based on the well-established torch series "MB" the RAB GRIP Fume Extraction Torches offer efficient fume extraction through the torch itself. Special design solutions guarantee highly efficient smoke removal directly at its source without affecting the protective gas shield.

- Direct extraction at the arc – ensures protection of the welder's respiratory system
- Problem free installation in all existing MIG/MAG work stations
- Small extraction tube diameter – better accessibility
- Aluminium extraction tube – considerable weight saving



- Handle with extraction control and swivel joint – optimized handling
- Smaller diameter extraction hoses for all types – lower handling weight, optimum flexibility
- Considerable weight reduction of air cooled torches due to the innovative ABICOR BINZEL Low-Weight Bikox®

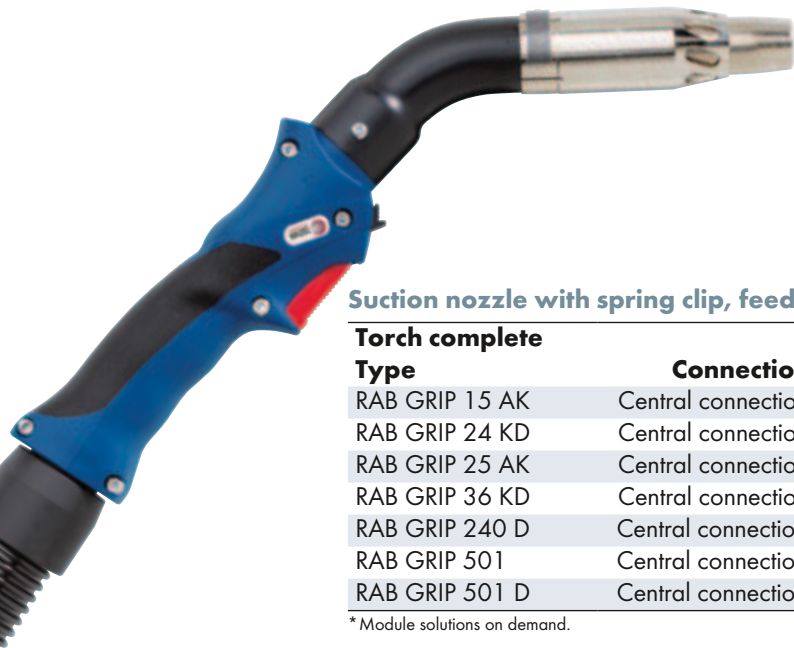

Suction nozzle with spring clip, feed air slide below*

Torch complete Type	Connection	Part-No.		
		3 m	4 m	5 m
RAB GRIP 15 AK	Central connection KZ-2	602.3001.1	602.3002.1	602.3003.1
RAB GRIP 24 KD	Central connection KZ-2	612.3001.1	612.3002.1	612.3003.1
RAB GRIP 25 AK	Central connection KZ-2	604.3001.1	604.3002.1	604.3003.1
RAB GRIP 36 KD	Central connection KZ-2	614.3001.1	614.3002.1	614.3003.1
RAB GRIP 240 D	Central connection WZ-2	623.3003.1	623.3004.1	623.3005.1
RAB GRIP 501	Central connection WZ-2	632.3003.1	632.3004.1	632.3005.1
RAB GRIP 501 D	Central connection WZ-2	634.3003.1	634.3004.1	634.3005.1

*Module solutions on demand.

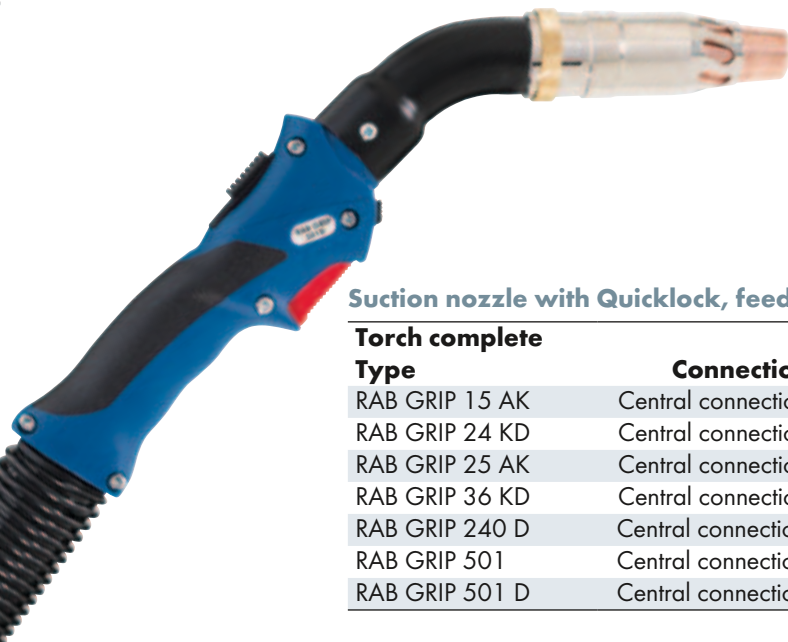

Suction nozzle with Quicklock, feed air slide on top

Torch complete Type	Connection	Part-No.		
		3 m	4 m	5 m
RAB GRIP 15 AK	Central connection KZ-2	602.3008.1	602.3009.1	602.3010.1
RAB GRIP 24 KD	Central connection KZ-2	612.3007.1	612.3008.1	612.3009.1
RAB GRIP 25 AK	Central connection KZ-2	604.3007.1	604.3008.1	604.3009.1
RAB GRIP 36 KD	Central connection KZ-2	614.3007.1	614.3008.1	614.3009.1
RAB GRIP 240 D	Central connection WZ-2	623.3011.1	623.3012.1	623.3013.1
RAB GRIP 501	Central connection WZ-2	632.3015.1	632.3016.1	632.3017.1
RAB GRIP 501 D	Central connection WZ-2	634.3030.1	634.3031.1	634.3032.1

RAB GRIP

RAB GRIP specific wear parts



Type	Suction nozzle spring clip	Suction nozzle Quicklock
RAB GRIP 15 AK	600.2047.1	600.3017.1
RAB GRIP 24 KD	600.2045.1	600.3018.1
RAB GRIP 25 AK	600.2046.1	600.3019.1
RAB GRIP 36 KD	600.2044.1	600.3009.1
RAB GRIP 240 D	600.2045.1	600.3018.1
RAB GRIP 501	600.2044.1	600.3009.1
RAB GRIP 501 D	600.2044.1	600.3009.1

Replacement spring clip for the fixation of the suction nozzle on request.
Suction funnel (replaces the suction nozzle) on request.

Type	Swan neck	Outer neck	Gas nozzle holder
RAB GRIP 15 AK	602.3004.1	600.3007.1	902.0007
RAB GRIP 24 KD	612.2001	600.2002	-
RAB GRIP 25 AK	604.2001	600.3007.1	-
RAB GRIP 36 KD	614.2001	600.2002	-
RAB GRIP 240 D	623.3001.1	600.2002	-
RAB GRIP 501	632.3001.1	632.2009	-
RAB GRIP 501 D	634.3001.1	600.2002	-

The wear parts - contact tip, gas nozzle, gas diffuser, contact tip holder, neck liner or liner - are identical with those of the manual welding torches of same size.

Technical Data

Type	Cooling	Rating		Duty cycle (%)	Wire size (mm)
		CO ₂	Mixed Gases M21		
RAB GRIP 15 AK	air	180 A	150 A	60	0.6-1.0
RAB GRIP 24 KD	air	250 A	220 A	60	0.8-1.2
RAB GRIP 25 AK	air	230 A	200 A	60	0.8-1.2
RAB GRIP 36 KD	air	300 A	270 A	60	0.8-1.2
RAB GRIP 240 D	liquid	300 A	270 A	100	0.8-1.2
RAB GRIP 501	liquid	550 A	500 A	100	1.0-1.6
RAB GRIP 501 D	liquid	500 A	450 A	100	1.0-1.6

Note for liquid cooled torches:

To protect cable assembly components from excessive heat build up we recommend a post welding cooling cycle of at least four minutes.

MIG/MAG Fume Extraction Torches in action ...



MIG/MAG **without** fume extraction



RAB GRIP **with** fume extraction

Fume Extraction System

FES-200 and FES-200 W3

Mobile, powerful and easy to use! The Fume Extraction System FES-200 - for optimum extraction of contaminants with fume extraction directly at the arc. The W3 version is certified for all CrNi-steels!

The high-vacuum extraction unit FES-200 and FES-200 W3 with the RAB GRIP torches constitutes the perfect system to extract welding fumes most effectively. Hence, the welder and his environment are best protected, and the most productive work enabled.

- Weighs approx. 23 kg
- Automatic Start/Stop function included in basic equipment
- Integrated manual filter cleaning system for longer uses
- A filter contamination meter; only clean when necessary
- IFA certified W3-License



The FES-200 W3 was developed specifically to meet the demands of chrome and nickel material joining, and is certified by the Institute of Work Safety with the **W3 license for all welding applications** or related procedures with emissions suitable to KMR / 1.2 materials*. Thus, this device enables the filtering of the exhaust, and work to be conducted without these otherwise harmful effects.

* List of carcinogenic, mutagenic, or toxic to reproduction materials

Fume Extraction System & Accessories

Complete extraction unit



Extraction unit package includes:

- Extraction hose with sleeve
- Start/Stop shunt
- 10 dust collection bags
- Filter cartridge

Replacement parts and accessories

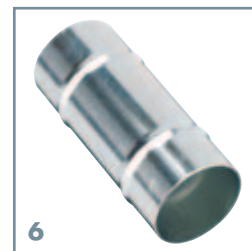
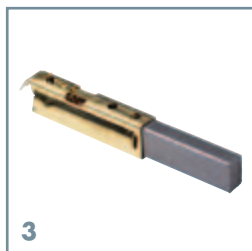

Pos.	Description	Part-No.
1	Complete unit FES-200 (230 V)	601.0001.1
	Complete unit FES-200 (115 V)	601.0002.1
2	Complete unit FES-200 W3 (230 V)	601.0034.1
3	Carbon brush (230 V)	601.0005.1
	Carbon brush (115 V)	601.0017.1
4	Filter cartridge FES-200	601.0008.1
	Filter cartridge FES-200 W3	601.0048.1
5	Hose with sleeve, L = 5.00 m	601.0015.1
6	Adapter ring (connection for two hoses)	601.0046.1
7	Start/Stop shunt, 7-pole	601.0020.1
not ill.	Start/Stop shunt, 4-pole	601.0041.1
8	Dust collection bag (w/o pan)	601.0021.10
9	Exhaust casting FES-200 (optional)	601.0023.1
10	Adapter ring FES-200 / RAB Plus (50 / 44 mm)	601.0031.1

MIG/MAG Machine Welding Torches

Air and liquid cooled

Machine welding processes are used wherever high precision and productivity is required. Accessibility to the components very often requires special solutions with mechanical torches. ABICOR BINZEL offers an almost infinite variety of solutions, always based on the design of the world-wide recognized manual torches.

This means, experience in service life and quality offers additional advantages, so that special parts are not required.

Your ABICOR BINZEL advantages:

- Expert competence
- Separate special torch production – short delivery time
- High availability
- Right solution for every job



Note for liquid cooled torches:

To protect cable assembly components from excessive heat build up we recommend a post welding cooling cycle of at least four minutes.



MIG/MAG Machine Welding Torches

Fixed swan neck

Type	Geometry	Part-No.	X	Y
AUT 24 KD	0°	912.0001	154 mm	
AUT 24 KD	45°	912.0002	125 mm	80 mm
AUT 25 KD	0°	904.0003	140 mm	
AUT 25 KD	45°	904.0004	110 mm	75 mm
AUT 26 / 36 KD	0°	914.0002	185 mm	
AUT 26 / 36 KD	45°	914.0001	145 mm	95 mm
AUT 240 D	0°	923.0001	154 mm	
AUT 240 D	45°	923.0002	126 mm	73 mm
AUT 501	0°	932.0001	167 mm	
AUT 501	45°	932.0002	135 mm	82 mm
AUT 501 D	0°	934.0001	167 mm	
AUT 501 D	45°	934.0002	135 mm	82 mm
ABIMIG® W 555 MT	0°	766.0878.1	175 mm	
ABIMIG® W 555 MT	22°	766.0879.1	168 mm	38 mm
ABIMIG® W 555 MT	45°	766.0880.1	144 mm	84 mm
ABIMIG® W 555 D MT	0°	766.0865.1	175 mm	
ABIMIG® W 555 D MT	22°	766.0866.1	168 mm	38 mm
ABIMIG® W 555 D MT	45°	766.0867.1	144 mm	84 mm
ABIMIG® W 605 MT	0°	766.0883.1	184 mm	
ABIMIG® W 605 MT	22°	766.0884.1	176 mm	41 mm
ABIMIG® W 605 MT	45°	766.0885.1	150 mm	90 mm
ABIMIG® W 605 D MT	0°	766.0871.1	183.5 mm	
ABIMIG® W 605 D MT	22°	766.0872.1	176 mm	41 mm
ABIMIG® W 605 D MT	45°	766.0873.1	150 mm	90 mm
ABIMIG® 645 W MT	0°	766.0459	182 mm	
ABIMIG® 645 W MT	45°	766.0460	149 mm	89 mm

Changeable swan neck

Type	Geometry	Part-No.	X	Y
ABIMIG® MT 255 T8M	0°	012.D122	195 mm	
ABIMIG® MT 255 T8M	45°	004.D785	140 mm	85 mm
ABIMIG® MT 355 T8M	0°	014.D812	224 mm	
ABIMIG® MT 355 T8M	45°	014.D808	185 mm	95 mm
ABIMIG® MT 455 T8M	0°	016.D250	230 mm	
ABIMIG® MT 455 T8M	45°	016.D225	190 mm	100 mm

Fixed swan neck

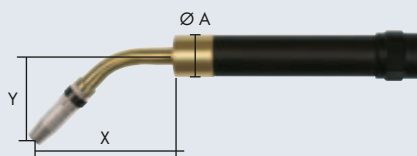

Ø A air cooled torches: 38 mm
liquid cooled torches: 38 mm

Changeable swan neck

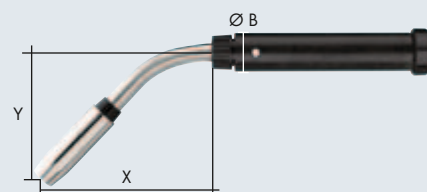

Ø B air cooled torches: 37 mm
liquid cooled torches: 40 mm

Order information:

When ordering complete torches, please indicate the torch type, torch geometry (straight or 45° bent) and dimension "L" (see sketch).

The wear parts - contact tip, gas nozzle, gas diffuser, contact tip holder, neck liner or liner - are identical with those of the manual welding torches of same size.

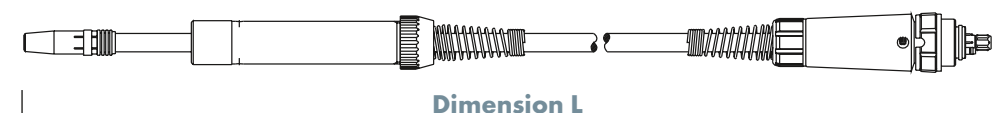

Bikox[®], Control cables, Hoses and Liners

I. Cable assemblies air cooled

Type	Bikox [®]	Cable assembly length			
		3 m	4 m	5 m	8 m
MB GRIP 15 AK	R4 / Type 16	160.D520	160.D521	160.D522	-
MB GRIP 24 KD / 26 KD	R6 / Type 35	160.D430	160.D431	160.D432	-
MB GRIP 25 AK	R5 / Type 25	160.D427	160.D428	160.D429	-
MB GRIP 36 KD	R7 / Type 50	160.D434	160.D435	160.D436	-
ABIMIG [®] GRIP A 155 LW / ABIMIG [®] A T 155 LW / RAB GRIP 15	R4 / LW	160.H025.1	160.H026.1	160.H027.1	-
ABIMIG [®] GRIP A 255 LW / ABIMIG [®] A T 255 LW / RAB GRIP 25	R5 / LW	160.H032.1	160.H033.1	160.H034.1	-
ABIMIG [®] GRIP A 305 LW / ABIMIG [®] A T 305 LW / RAB GRIP 24	R6 / LW	160.H039.1	160.H040.1	160.H041.1	-
ABIMIG [®] GRIP A 355 LW / ABIMIG [®] A T 355 LW / RAB GRIP 36	R7 / LW	160.H046.1	160.H047.1	160.H048.1	-
ABIMIG [®] GRIP A 405 LW / ABIMIG [®] A T 405 LW	R9 / LW	160.H344.1	160.H345.1	160.H346.1	-
PP Plus 36 D	Type 35	-	-	-	118.0074

II. Cable assemblies liquid cooled

Type	Description	Cable assembly length				per m
		3 m	4 m	5 m	8 m	
MB GRIP 240 / 401 / 501	Power cable HDH	115.0065	115.0070	115.0074	-	-
ABIMIG [®] GRIP W 555 / 605	Power cable PVC	115.0581	115.0582	115.0583	-	-
RAB GRIP 240 / 501	Power cable PVC	115.0581	115.0582	115.0583	-	-
PP Plus 240 / 401	Power cable PVC	-	-	-	115.0043	-
MB GRIP 240 / 401 / 501	Wire conduit	156.0275	156.0276	156.0277	-	-
ABIMIG [®] GRIP W 555 / 605	Wire conduit	156.0275	156.0276	156.0277	-	-
RAB GRIP 240 / 501	Wire conduit	154.0002	154.0003	154.0004	-	-
PP Plus 240 / 401	Wire conduit	-	-	-	156.0273	-
MB GRIP 240 / 401 / 501	Water hose black HDH	-	-	-	-	109.0052
ABIMIG [®] GRIP W 555 / 605	Water hose blue PVC	-	-	-	-	109.0057
ABIMIG [®] GRIP W 555 / 605	Water hose red PVC	-	-	-	-	109.0056
RAB GRIP 240 / 501	Water hose blue PVC	-	-	-	-	109.0057
RAB GRIP 240 / 501	Water hose red PVC	-	-	-	-	109.0056
PP Plus 240 / 401	Water hose blue PVC	-	-	-	-	109.0057
PP Plus 240 / 401	Water hose red PVC	-	-	-	-	109.0056
MB GRIP 240 / 401 / 501	Gas hose	-	-	-	-	109.0040
ABIMIG [®] GRIP W 555 / 605	Gas hose	-	-	-	-	109.0040
RAB GRIP 240 / 501	Gas hose	-	-	-	-	109.0040
PP Plus 240 / 401	Gas hose	-	-	-	-	109.0040
All torches	Control cable 2-pole	-	-	-	-	100.0019

Bikox[®], Control cables, Hoses and Liners

III. Outer and Suction Hose

Type	Description	Cable assembly length			
		3 m	4 m	5 m	per m
MB GRIP 240 / 401 / 501	Outer hose 25x1.5	-	-	-	107.0004
ABIMIG [®] GRIP W 555 / 605	Outer hose 25x1.5	-	-	-	107.0004
RAB GRIP 15 / 24 / 25 / 36	Outer hose LW 32	-	-	-	109.0043
RAB GRIP 240 / 501	Outer hose LW 38	-	-	-	109.0044
PP Plus 36 / 240 / 401	Outer hose 25x1.5	-	-	-	107.0004

IV. Hose clamps, Quick connector and Marking washer

Type	Pcs.	Part-No.	for hose			
			109.0040	109.0052	109.0056	109.0057
Hose clamp Ø=8.7	100	171.0002	•			
Hose clamp Ø=9.0 with ring (mark. 9.5)	100	173.0001			•	•
Hose clamp Ø=9.5 with ring (mark.10.0)	100	173.0002		•		
Quick connector NW 5 / Ø=6.0	20	501.0114		•	•	•
Marking washer red	20	501.2166		•		
Marking washer blue	20	501.2167		•		
Fastener cap red	20	501.2423		•	•	
Fastener cap blue	20	501.2424		•		•

V. Combined wire guides

Type	for wire size	for 3 m	for 4 m	for 5 m	for 8 m
PTFE / Brass	0.8	126.M002	126.M003	126.M004	-
PTFE / Brass	1.0-1.2	126.M006	126.M007	126.M008	-
PTFE / Brass	1.6	126.M009	126.M010	126.M011	-
Carbon-PTFE / Brass	0.8	127.M002	127.M003	127.M004	-
Carbon-PTFE / Brass	1.0-1.2	127.M006	127.M007	127.M008	-
PA / Brass	1.0-1.2	128.M002	128.M003	128.M004	-
P (for ABIMIG [®] A / A T 405 LW)	1.0	126.D026.1	126.D027.1	126.D028.1	
P (for ABIMIG [®] A / A T 405 LW)	1.2-1.4	126.D029.1	126.D030.1	126.D031.1	

VI. Liner for special wire

Liner	Color	Ø inside / outside	for wire size	for 3 m	for 4 m	for 5 m	for 8 m
PA liner	grey	2.0 / 4.0	1.0-1.2	128.0012	128.0015	128.0016	128.0019
PA liner	grey	2.3 / 4.7	1.6	128.0020	128.0021	128.0030	128.0023
PA liner	grey	2.9 / 4.7	2.4	128.0024	128.0025	128.0027	128.0032

Handles and control modules

VII. Handles / Handle tubes

Type	Description	Part-No.
MB GRIP 15 / 24 / 25 / 26 / 36	Handle Type MB GRIP	180.0127
Ball joint cable protection MB GRIP	air cooled	400.1395.1
MB GRIP 240 / 401 / 501	Handle Type MB GRIP	180.0127
Ball joint cable protection MB GRIP	liquid cooled	400.1392.1
Inner ring MB GRIP	for ball joint cable protection (400.1392.1), liquid cooled	400.0790
ABIMIG® GRIP A LW 155 / 255 / 305 / 355	Handle Type MB GRIP	180.0127
Ball joint cable protection short ABIMIG® GRIP A LW	air cooled	400.1323.1
ABIMIG® GRIP A 405 LW	Handle Type ABIMIG® GRIP S	180.0132.1
Ball joint cable protection short ABIMIG® GRIP A LW	air cooled	400.1323.1
ABIMIG® GRIP W 555 / 605	Handle Type ABIMIG® GRIP S	180.0132.1
Ball joint cable protection ABIMIG® GRIP W	liquid cooled	400.1392.1
Inner ring ABIMIG® GRIP W	for ball joint cable protection (400.1392.1), liquid cooled	400.0790
AUT 24 / 25 / 26 / 36 / 240 / 401 / 501	Handle tube AUT	180.0097
ABIMIG® W MT 555 / 605 / 645	Handle tube MT	180.0114

VIII. Handle Type SH and control modules / Handle Type TO and control modules

Type	Description	Details	Part-No.
All ABIMIG® GRIP Torches	Handle Type ABIMIG® GRIP SH, without control module		180.0133.1
All ABIMIG® GRIP Torches	Control module with potentiometer left 10 kΩ	BIS-01L	400.0956
	Control module with potentiometer right 10 kΩ	BIS-01R	400.0957
	Control module with potentiometer left 10 kΩ LED for Migatronic	BIS-02	400.0958
	Control module with push-button and 4 LED	BIS-06	400.0959
	Control module Up/Down 7-segment switch crosswise	BIS-07B	400.0961
	Control module Up/Down switch lengthwise	BIS-10A	400.0963
	Control module Up/Down switch crosswise	BIS-10B	400.0964
	Control module Up/Down switch crosswise for Fronius	BIS-10D	400.1085
	Control module Up/Down 2x switch lengthwise for EWM	BIS-13A	400.0966
	Control module Up/Down 2x push-button for Cloos	BIS-18	400.1545.1
	Control module push-button 3-step	BIS-19	400.1088
All ABIMIG® GRIP Torches	Handle Type ABIMIG® GRIP TO (top trigger)		180.0134.1

IX. Adapter

Type	Description	Part-No.
For all torch types MB ERGO / MB GRIP / ABIMIG® GRIP 155-355	For use of handle type ABIMIG® GRIP / ABIMIG® GRIP SH / ABIMIG® GRIP TO	400.1341.1

Handles and control modules

Handle Type "MB GRIP"



Part-No.: 180.0127

Handle Type " ABIMIG® GRIP S"



Part-No.: 180.0132.1

Handle Type "ABIMIG® GRIP TO"

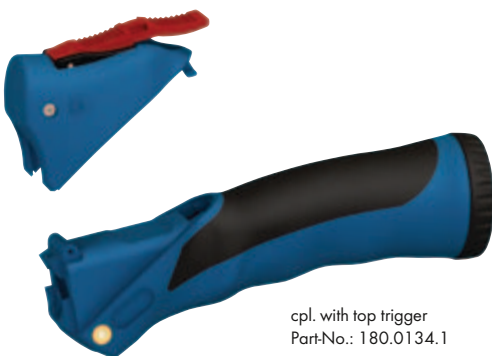

cpl. with top trigger
Part-No.: 180.0134.1

Adapter



for all torch types MB ERGO / MB GRIP / ABIMIG® GRIP 155-355
for using the handles Type ABIMIG® GRIP / ABIMIG® GRIP SH / ABIMIG® GRIP TO
Part-No.: 400.1341.1

Handle Type "ABIMIG® GRIP SH"



BIS-01L
Control module with potentiometer
left 10 kΩ



BIS-01R
Control module with potentiometer
right 10 kΩ



BIS-02
Control module with potentiometer
left 10 kΩ LED for Migatronik



BIS-06
Control module with push-button and 4 LED



BIS-07B
Control module Up/Down 7-segment
switch crosswise



BIS-10A
Control module Up/Down switch lengthwise



BIS-10B
Control module Up/Down switch crosswise



BIS-10D
Control module Up/Down switch crosswise
for Fronius



BIS-13A
Control module Up/Down 2x switch
lengthwise for EWM



BIS-18
Control module Up/Down 2x push-button
for Cloos



BIS-19
Control module push-button 3-step



incl. add-on for control modules

Part-No.: 180.0133.1

Handles and Modules

X. Handle ABIMIG® A T LW without Modules

Type	Description	Part-No.
ABIMIG® A T LW 155 / 255 / 305 / 355 / 405	Handle push-button long, blind cover	180.D077.1
ABIMIG® A T LW 155 / 255 / 305 / 355 / 405	Handle push-button short, blind cover	180.D078.1
Cable protection ABIMIG® A T LW	short	400.D574.1
Half rings (fixes cable protection on handle)	1 pair	400.D561.2

Handle Type "ABIMIG® A T LW"



Push-button long, blind cover
Part-No.: 180.D077.1

Handle Type "ABIMIG® A T LW"



Push-button short, blind cover
Part-No.: 180.D078.1

XI. Handle ABIMIG® A T LW with Module

Type	Description	Part-No.
ABIMIG® A T LW 155 / 255 / 305 / 355 / 405	Handle push-button long, incl. Module BIS-52 Up/Down 2x push-button (400.1292.1)	180.D079.1
ABIMIG® A T LW 155 / 255 / 305 / 355 / 405	Handle push-button short, incl. Module BIS-52 Up/Down 2x push-button (400.1292.1)	180.D080.1
Cable protection ABIMIG® A T LW	short	400.D574.1
Half rings (fixes cable protection on handle)	1 pair	400.D561.2

Handle Type "ABIMIG® A T"



Push-button long, Up/Down
Part-No.: 180.D079.1

Handle Type "ABIMIG® A T"



Push-button short, Up/Down
Part-No.: 180.D080.1

Handles and Modules

XII. Handles RAB GRIP without Modules

Type	Description	Part-No.
RAB GRIP 15 / 24 / 25 / 36 / 240 / 501	Handle Type Standard (feed air slide below)	180.0138.1
RAB GRIP 15 / 24 / 25 / 36 / 240 / 501	Handle Type ZO (feed air slide on top)	180.0144.1
Connector RAB GRIP 15 / 24 / 25 / 36	air cooled	600.2008
Connector RAB GRIP 240 / 501	liquid cooled	600.0080

Handle Type "RAB GRIP Standard"



Push-button, feed air slide below
Part-No.: 180.0138.1

Handle Type "RAB GRIP ZO"



Push-button, feed air slide on top
Part-No.: 180.0144.1

XIII. Handles RAB GRIP with Modules

Type	Description	Part-No.
RAB GRIP 15 / 24 / 25 / 36 / 240 / 501	Handle Type SH without module (feed air slide below)	180.0154.1
Connector RAB GRIP 15 / 24 / 25 / 36	air cooled	600.2008
Connector RAB GRIP 240 / 501	liquid cooled	600.0080
Module push-button	BIS-51	400.1296.1
Module Up/Down 2x push-button	BIS-52	400.1292.1

Handle Type "RAB GRIP SH"



Push-button, feed air slide below
Part-No.: 180.0154.1



BIS-51
Control module push-button



BIS-52
Control module Up/Down
2x push-button

Central adaptor and central connector system

The universal connection ...

The original ABICOR BINZEL central adaptor and central connector, for air and liquid cooled MIG/MAG machines, have been the industry standard for more than 40 years.

All machine types are different in construction and all wire feeding systems have their own dimensions. However, there is a common denominator the central adaptor system from ABICOR BINZEL.

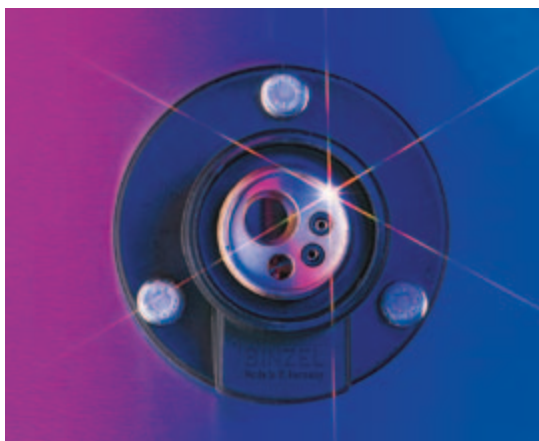
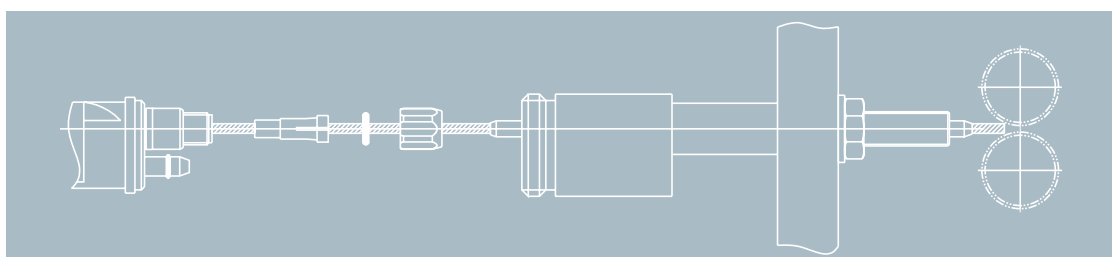

We offer more than 500 different central adaptor types. Please indicate manufacturer and type of your wire feeder or your compact power source and we will supply you with the appropriate adaptor. However, if an adaptation problem should occur, please contact us - we will take care of it.

Central adaptor and central connector system

Insulation flanges

Description	Pos.	Details	Part-No.
Insulation flange	not ill.	Ø 120 mm	501.0602
Insulation flange	1	Δ 85 mm	501.2381
Insulation flange	2	Ø 85 mm	501.0616
Insulation flange	3	Ø 50 mm	501.0588
Insulation flange	not ill.	□ 60 mm	501.2308



Brass bodies

Description	Pos.	Details	Part-No.
Brass body	4	Gas axial	501.0168
Brass body	5	Gas axial	501.0169
Brass body	6	Power / Gas radial	501.0170
Brass body	7	Power and Gas radial	501.0172
Brass body	8	Power radial / Gas axial	501.0175
Connector with control line	not ill.	600 mm (white)	501.0183
Connector with control line	not ill.	600 mm (brown)	501.2020

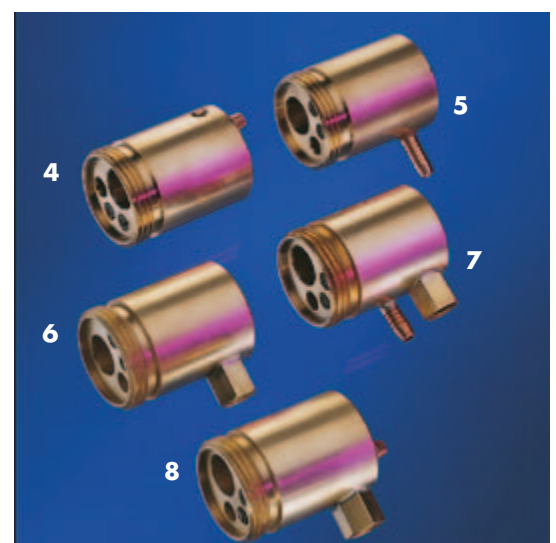

Adaptor plugs

Description	Pos.	Details	Part-No.
Blank Ø 16	9	100 mm	501.2191
Blank Ø 16	10	170 mm	501.2192
Blank Ø 16	11	250 mm	501.2193
Blank Ø 22	12	200 mm	501.2190

Here you can see a small selection of adaptor plug blanks for individual adaption, representing more than 500 different adaptor plugs available in the ABICOR BINZEL range.

We supply ready made adaptors on request, please specify the make and type of wire feeding device and/or compact machine in your order.

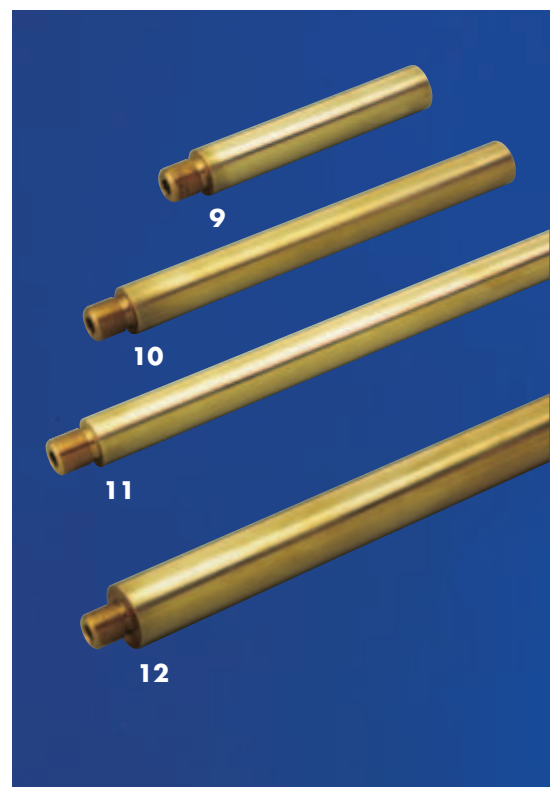

Description	Part-No.
Power lug	501.0280

Central adaptor and central connector system



Capillary tubes

Description	Details	Part-No.
Capillary tubes for wire up to Ø 1.0 mm	200 mm	129.0164
	300 mm	129.0187
	500 mm	129.0189
Capillary tubes for wire up to Ø 1.6 mm	1000 mm	129.0107
	200 mm	129.0313
	300 mm	129.0357
Capillary tubes for wire Ø 2.0 and 2.4 mm	500 mm	129.0361
	1000 mm	129.0227
	200 mm	129.0395
	300 mm	129.0411
	500 mm	129.0412
	1000 mm	129.0366

Guide tubes

Description	Details	Part-No.
Guide tubes for liners	200 mm	129.0461
Guide tubes for liners	300 mm	129.0471
Guide tubes for liners	500 mm	129.0473
Guide tubes for liners	1000 mm	129.0426

The guide tubes must be fitted as shown in the assembly instructions on page 41.

Central adaptor and central connector system

Assembly instruction for use of PTFE- and plastic liners:

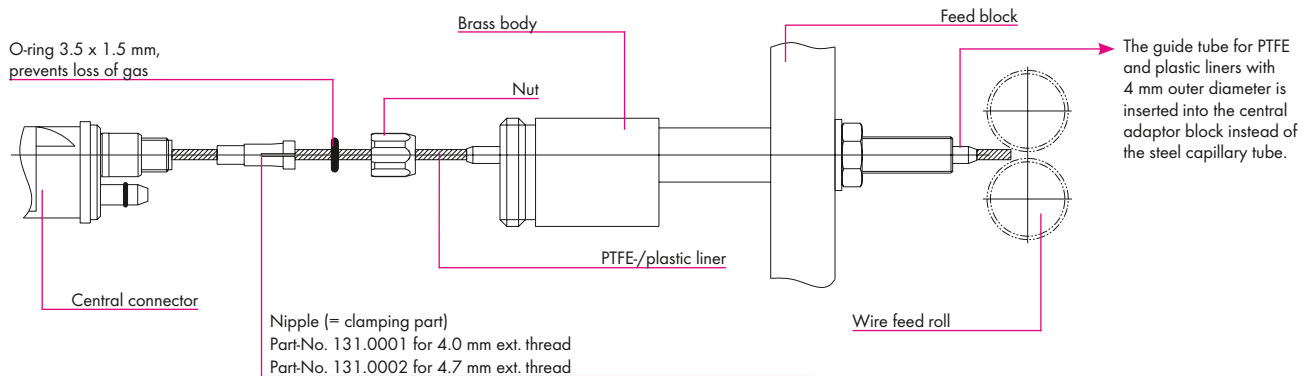

Dimension sketch for central adaptors (please insert the exact dimensions and send back by fax or e-mail):

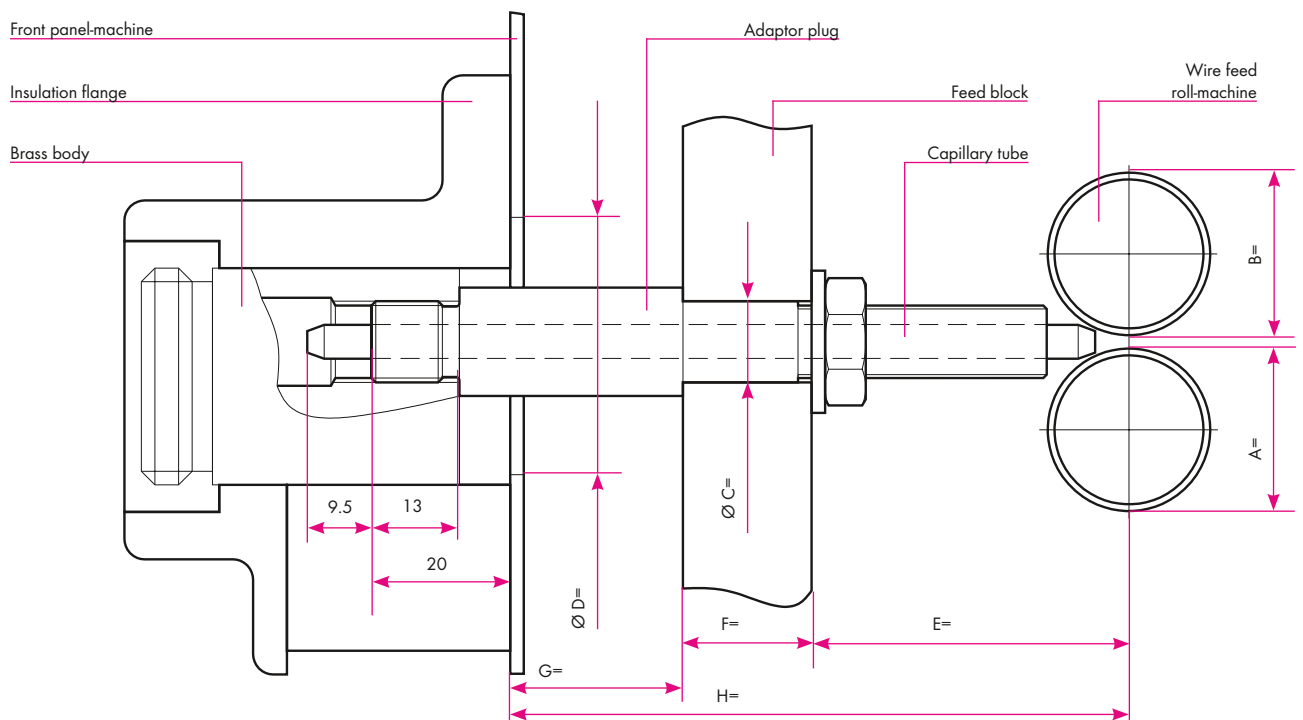

	Power source	Wire feeder
Manufacturer		
Type		
Serial No.		
Constr. year		

	Connections Plug conn.	Thread	Hose cable length (in mm)	Connections inside	Connections outside
Gas					
Current					
Water preflow					
Current / Water					
Control lead	1 <input type="checkbox"/>	2 <input type="checkbox"/>	3 <input type="checkbox"/>		

Sender

Company:	
Street / No.:	
Post code:	
City:	

Name:	
Phone:	
Fax:	
Date:	
Signature:	

Hint:
Copy this page so you can use it several times.

Central adaptor with spring contacts

Flexible contact ...

The system works!
No matter what happens.

Whether the contact guides have become slightly damaged due to rough operating conditions or have even been deformed by improper handling – this central adaptor will ensure a safe contact even with female connectors from other manufacturers.



The new original.
 The new central adaptor with flexible spring contacts.

Because when the adaptor and female connector are joined together, the contact pins on the adaptor are no longer inserted into the female connector. Instead, hemispherical contact is made with the insertion openings, whereby spring force ensures additional contact pressure.

Even in the case of misuse or the wrong female connectors nothing can happen, nothing becomes bent. Because the contact pins then retract flexibly. For longer service life and better contact!

Central adaptor with spring contacts

Type	Description	Part-No.
Central adaptor KZ-2	for MB ERGO / MB GRIP / ABIMIG® GRIP A LW 155-355 / ABIMIG® A T LW 155-355 / RAB GRIP, air cooled	501.0003
Central adaptor WZ-2	for MB ERGO / MB GRIP / ABIMIG® / Push-Pull Plus / RAB GRIP, liquid cooled	501.0015
Central adaptor GZ-2	for Push-Pull Plus, air cooled	501.0018
Adaptor with control line	100 mm (white)	501.2539.10
Adaptor with control line	100 mm (brown)	501.2538.10

The central adaptor that always produces a good connection thanks to its flexible spring contacts.



Notes

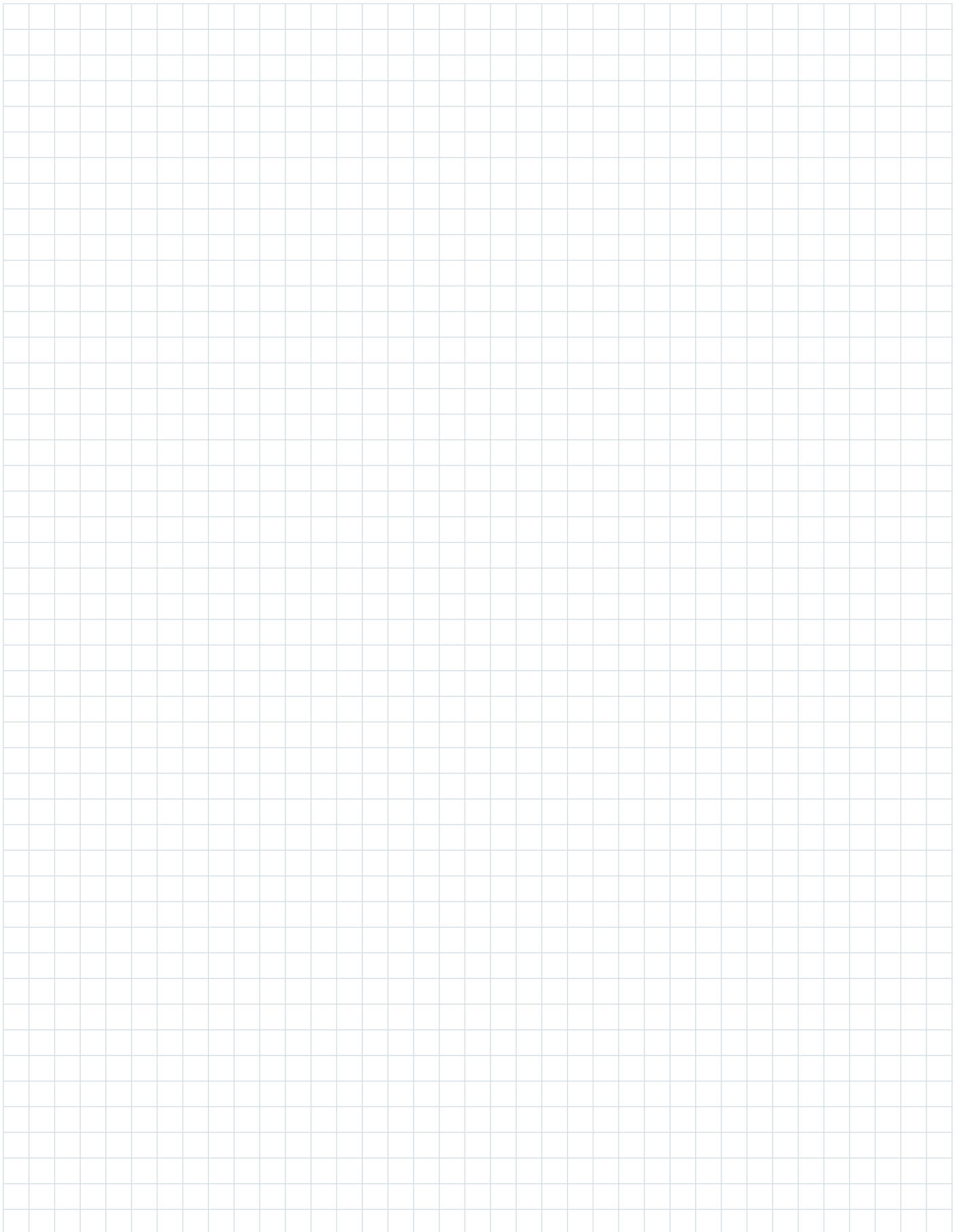

Our product range:

■ MIG/MAG

- Welding Torches
- Machine and Special Torches
- Push-Pull Welding Torches
- Fume Extraction Torches
- Central Adaptor System

■ WIG

- Welding Torches
- Machine and Special Torches

■ PLASMA

- Cutting Torches
- Welding Torches
- Machine and Special Torches

■ Robotic Peripheral Equipment

- Robot Torches
MIG/TIG/Plasma
- Robot Mount CAT2/iCAT
- Torch Change System
ATS-Rotor
- Tool Change System WWS
- Wire Cutting Station DAV
- Torch Cleaning Station
BRS-LC, BRS-CC and BRS-FP
- Wire Feeding Station APD-MF

■ Welding Accessories

- Coolers
- Welding Cable Plug and Socket
- Anti Spatter Spray and Paste
and so on ...

ABICOR
BINZEL® 

Alexander Binzel Schweisstechnik GmbH & Co. KG
P.O. Box 10 01 53 · D-35331 Giessen
Phone: +49 (0) 64 08 / 59-0
Fax: +49 (0) 64 08 / 59-191
Email: info@binzel-abicor.com

www.binzel-abicor.com