



# BLUE TORCH II

CO<sub>2</sub> / MAG / MIG WELDING TORCH



## The Most Advanced ULTIMATE CO<sub>2</sub>/MAG/MIG WELDING TORCH from thorough quest for user friendliness



- Super Ergonomic grip for easy operation
- Extensive selection from 180A to 500A
- Improved connection design features more durability
- Using spring support at joint that subdues bending cable and delivers smooth wire feeding and reduced wire feeding troubles

## FULL LINE UP!

AUTOMATIC and ALUMINUM  
**BLUE TORCH II** available



OTC DAIHEN Asia Co., Ltd.



Certificate TH04/0450

# Endless evolution in seeking usability Ultimate Welding Torch !!

## Extensive Product Line from 180A to 500A Including New Aluminum & Stainless Torches

### Feature 1

Ergonomic design and soft grip delivers operators less fatigue for a long time welding operation

(WT3510, WT3520, WT5000, WTA300, WTS300)



### Feature 2

Consumable Parts are compatible with conventional Blue Torch Series (For example Nozzle, Orifice and Tip, etc)



### Feature 3

Soft and flexible coaxial cable delivers superior wire feeding and durability

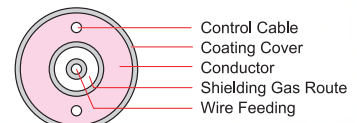

### Feature 4

Using spring at joint that subdues bending cable and delivers smooth wire feeding and reduced wire feeding troubles



### Feature 5

Improved connection design features more durability



### Welding Quality

We seek ideal torch everyday on every point of view and perform High Level Experiments thoroughly such as Gas Flow Test by laser schlieren method.



### Usability

Central connection applied on also "WTAW400-SD" water cooled torch for aluminum. This delivers a quick installation of torch.



## Water Cooled Torch for Aluminum & Wire Feeder of Simple Desorption coming in New Line Up !

No tool required for connecting water cooled torch and wire feeder for water cooled torch.

Wire feeder for water cooled torch requires no tool connection for both water cooled torch and air cooled torch.

One touch Connection without any Tools



WTAW400-SD

CMAW-7401







MODEL	CMAW-7401
APPLICABLE WIRE SIZE	(0.1), 1.2, 1.6mm
WIRE MATERIALS	Mild Aluminum
WEIGHT	15kg
OUTSIDE SIZE(W×D×H)	263×763×405mm

# CO<sub>2</sub>/MAG/MIG WELDING TORCH

# BLUE TORCH II







## CO<sub>2</sub>/MAG TORCH (15 Models Line Up from 180A to 500A)

RATED CURRENT	180A (CO <sub>2</sub> ) / 130A (MAG)	200A (CO <sub>2</sub> ) / 160A (MAG)	350A (CO <sub>2</sub> ) / 200A (MAG)	350A (CO <sub>2</sub> ) / 300A (MAG)	350A (CO <sub>2</sub> ) / 350A (MAG)	500A (CO <sub>2</sub> ) / 450A (MAG)
MODEL	WT1800-S	WT2000-S (M)	WT3500-S (M·L)	WT3510-S (M·L)	WT3520-S (M·L)	WT5000-S (M·L)
						
RATED DUTY CYCLE	40% (CO <sub>2</sub> ) / 30% (MAG)	50% (CO <sub>2</sub> ) / 30% (MAG)	30% (CO <sub>2</sub> ) / 30% (MAG)	60% (CO <sub>2</sub> ) / 30% (MAG)	80% (CO <sub>2</sub> ) / 30% (MAG)	60% (CO <sub>2</sub> ) / 30% (MAG)
APPLICABLE WIRE SIZE	(0.6) 0.8 mm	(0.8) 0.9 (1.0) (1.2) mm	(0.9) (1.0) 1.2 mm	(0.9) (1.0) 1.2 (1.4) mm	1.2 (1.4) (1.6) mm	(1.2) 1.4 (1.6) mm
CABLE LENGTH	3 m	3, 4 m	3, 4.5, 6 m	3, 4.5, 6 m	3, 4.5, 6 m	3, 4.5, 6 m
COOLING METHOD	AIR COOLED	AIR COOLED	AIR COOLED	AIR COOLED	AIR COOLED	AIR COOLED

TORCH of more than 350A as RATED CURRENT, it isn't possible to use 0.9mm Wire by 4.5m Cable and 0.9 and 1.0mm Wire by 6m Cable.



## Aluminum & Stainless TORCH (5 Models Line Up from 180A to 400A)

RATED CURRENT	180A	200A	300A		400A
MODEL	WTA180-S	WTA200-S	WTA300-S	WTS300-S	WTAW400-S ※
					
RATED DUTY CYCLE	20 % (MIG)	60%(MIG) / 30% (Pulsed MIG)	50%(MIG) / 30% (Pulsed MIG)	50 % (MIG/MAG)	100 %
APPLICABLE WIRE SIZE	0.8 mm	(1.0) 1.2 mm	(1.0) 1.2 (1.6) mm	Stainless (0.9) (1.0) 1.2 mm	1.2 (1.6) mm
CABLE LENGTH	2 m	3 m	3 m	3 m	3 m
COOLING METHOD	AIR COOLED	AIR COOLED	AIR COOLED	AIR COOLED	WATER COOLED

※. This Torch should be use with CMAW-7401(Central Connection Wire Feeder) only.

### MODEL NUMBER of Blue Torch II Series

# WT (A) 35 10 (F) - SD

**Blue Torch II**  
WT : Fe  
WTA : Al  
WTS : Stainless  
WTAW : Al  
(Water Cooled)

**RATED CURRENT**  
(350A)

**Series No.**

**Flexible type**

**Cable Length**  
S(Standard) : 3.0m ※1  
M(Middle) : 4.5m ※2  
L(Long) : 6.0m

#### Wire Feeder Connection

D : DAIHEN  
DB : DAIHEN Black Torch ※3  
P : Panasonic  
E : Euro(Binzel)  
FS : DAIDEN(FS Series) ※4  
DM : DAIDEN(MOVE Series) ※4  
M : Miller  
MS : Miller (Separate GAS Hose) ※3  
H : Hobart(Tweco)  
L : Lincoln  
HT : (Hitachi)  
One touch Connection is possible by attachment Adaptor to Other Brand Wire Feeder

MODEL	Power Cable Adaptor	Outlet Guide	Guide Adaptor
WT1800		U2770K01 (0.6-0.8)	U785C13
WT2000	U2772G00	U2075J03 (0.8-1.0)	
WT3500	U3286G00	U69B34 (0.9-1.2)	U785C13
WT3510	U2853G00		
WT3520		U69B35 (1.2-1.6)	
WT5000	U2774G00		

※1. WTA180-SD : 2m  
※2. WT2000-MD : 4m  
※3. Cable Adaptor, Guide Adaptor and Outlet Guide shown above are not included in Torch Unit. (Please order them separately, if it is necessary.)  
※4. If connection Adaptor for Blue Torch with Wire Feeder, please use Standard Adaptor(D: DAIHEN)



## WT1800 (180A) / WT2000 (200A)

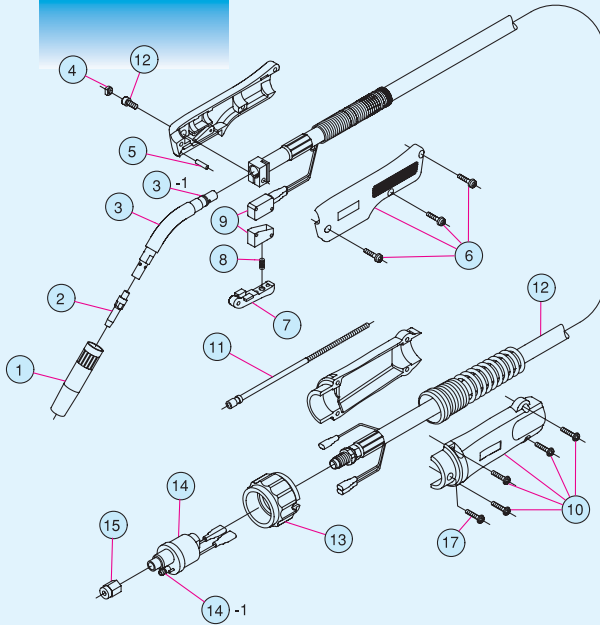

No.	Parts Description	WT1800 Type		WT2000 Type	
		S(D)	M(D)	S(D)	M(D)
①	NOZZLE	U4186L00		U5342N00	
②	TIP	K980C23		K980C24	
③	TORCH BODY			U5020C00	
③ -1	O-RING(S9)			3574-001	
④	CAP			U5341G01	
⑤	FLAT PIN			100-0311	
⑥	HANDLE (With Screw M4 × 18 : 3pc)			U5030G00 (M4 × 18 : 3 pc.)	
⑦	TRIGGER			U5030E01	
⑧	SPRING			U2853C04	
⑨	MICRO SWITCH			U4167T00 (With Switch Cover)	
⑩	CABLE SUPPORT (With Screw M4 × 16 : 4pc)			U5035K00	
⑪	LINER(3m)	U4353G01		U4186G01	—
	LINER(4m)	—	—	—	U4187G01
⑫	POWER CABLE(3m)(With Screw M5 × 14)	U5341D00		U5342D00	—
	POWER CABLE(4m)(With Screw M5 × 14)	—	—	—	U5343D00
⑬	ADAPTOR NUT			U4167F03	
<b>Optional Parts</b>					
⑭	ADAPTOR(With Screw M4 × 8)			U4167E00	
⑭ -1	O-RING			3570-125	
⑮	LINER NUT			U4167G06	

## WT3500 (350A)

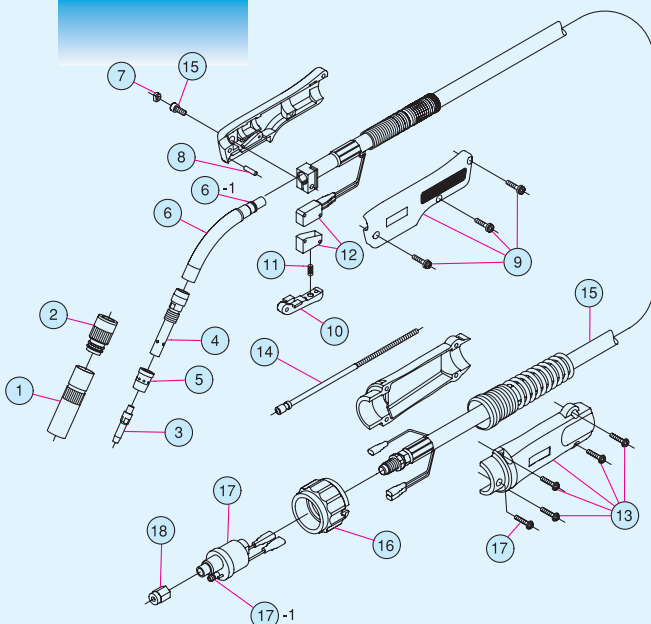

No.	Parts Description	WT3500 Type		
		S(D)	M(D)	L(D)
①	NOZZLE		U4167G01	
②	INSULATOR		U4167L00	
③	TIP		K980C26	
④	TIP BODY		U4170G03	
⑤	ORIFICE		U4167G02	
⑥	TORCH BODY		U5344B00	
⑥ -1	O-RING(S9)		3574-001	
⑦	CAP		U5341G01	
⑧	FLAT PIN		100-0311	
⑨	HANDLE(With Screw M4 × 18 : 3pc)		U5030G00 (M4 × 18 : 3 pc.)	
⑩	TRIGGER		U5030E01	
⑪	SPRING		U2853C04	
⑫	MICRO SWITCH		U4167T00 (With Switch Cover)	
⑬	CABLE SUPPORT(With Screw M4 × 16 : 4pc)		U5035K00	
⑭	LINER(3m)	U4170H02	—	—
	LINER(4.5m)	—	U4535G01	—
	LINER(6m)	—	—	U4172H01
⑮	POWER CABLE(3m)(With Screw M5 × 14)	U5344D00	—	—
	POWER CABLE(4.5m)(With Screw M5 × 14)	—	U5345D00	—
	POWER CABLE(6m)(With Screw M5 × 14)	—	—	U5346D00
⑯	ADAPTOR NUT		U4167F03	
<b>Optional Parts</b>				
⑰	ADAPTOR(With Screw M4 × 8)		U4167E00	
⑰ -1	O-RING		3570-125	
⑱	LINER NUT		U4167G06	

**WT3510 (350A)**  
**WT3520 (350A)**  
**WT5000 (500A)**

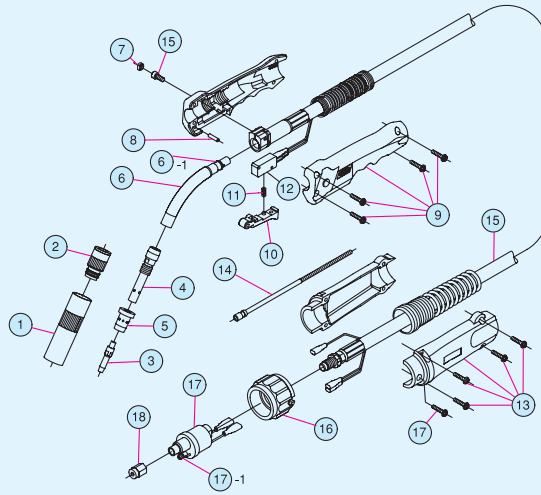

No.	Parts Description	WT3510 Type			WT3520 Type			WT5000 Type		
		S(D)	M(D)	L(D)	S(D)	M(D)	L(D)	S(D)	M(D)	L(D)
①	NOZZLE	U4167G01			U4167H16			U4173G01		
②	INSULATOR	U4167L00						U4173L00		
③	TIP	K980C26			K980C73			K980C74		
④	TIP BODY	U4167G03						U4173G21		
⑤	ORIFICE	U4167G02						U4173G02		
⑥	TORCH BODY	U5347B00			U5350B00			U5353B00		
⑥-1	O-RING(S9)				3574-001					
⑦	CAP				U5341G01					
⑧	FLAT PIN				U5035G03					
⑨	HANDLE (With Screw M4×20 : 2pc, M4×16 : 2pc)				U5035G00					
⑩	TRIGGER				U5035E01					
⑪	SPRING				U157E04					
⑫	MICRO SWITCH				4254-137					
⑬	CABLE SUPPORT(With Screw M4×16 : 4pc)				U5035K00					
⑭	LINER(3m)	U4170H02	—	—	U4173G04	—	—	U4173G04	—	—
	LINER(4.5m)	—	U4535G01	—	—	U4537G01	—	—	U4537G01	—
	LINER(6m)	—	—	U4172H01	—	—	U4175G04	—	—	U4175G04
⑮	POWER CABLE(3m)(With Screw M5×14)	U5347D00	—	—	U5350D00	—	—	U5353D00	—	—
	POWER CABLE(4.5m)(With Screw M5×14)	—	U5348D00	—	—	U5351D00	—	—	U5354D00	—
	POWER CABLE(6m)(With Screw M5×14)	—	—	U5349D00	—	—	U5352D00	—	—	U5355D00
⑯	ADAPTOR NUT				U4167F03					
<b>Optional Parts</b>										
⑰	ADAPTOR(With Screw M4×8)				U4167E00					
⑰-1	O-RING				3570-125					
⑱	LINER NUT				U4167G06					

● **By Exchange NOZZLE, Workability will progress**

MODEL	STANDARD SET PARTS				OPTIONAL NOZZLE			
	TIP BODY	INSULATOR	ORIFICE	NOZZLE	LOW CURRENT	MID/HIGH CURRENT	ARC SPOT	DEEP/NARROW SPACE
WT1800-SD				U4186L00 77.5 		U4186P00 77.5 	U4186M00 85.5 	U4186R00 103 
WT2000-SD (MD)				U5342N00 75.5 		U5342P00 75.5 	U5342Q00 83.5 	Please combine with LONG TIP.
WT2000F-SD (MD)				U4170G03 71.5 		U4167H16 73 	U4170H01 81 	U4167H04 100 
WT3500-SD (MD, LD)				U4167G01 73 		U4167H16 73 	U4170H01 81 	U4167H04 100 
WT3510-SD (MD, LD) WT350PD (PA, RD, RA)				U4167H16 73 		U4167H02 77 	U4167H03 88 	Please combine with LONG TIP.
WT3520-SD (MD, LD)				U4167G01 73 		U4167H16 73 	U4170H01 81 	LONG TIP 61.5 
WT3500F-SD (MD, LD)				U4167G01 73 		U4167H16 73 	U4170H01 81 	WIRE PART NO.
WT3510F-SD (MD, LD)				U4167H16 73 		U4167H02 77 	U4167H03 88 	0.8 U4167H08
WT3520F-SD (MD, LD)	U4167H16 73 	U4167H02 77 	U4167H03 88 	0.9 U4167H07				
WT3500F-SD (MD, LD)	U4167H16 73 	U4167H02 77 	U4167H03 88 	1.0 U4167H06				
WT3520F-SD (MD, LD)	U4167H16 73 	U4167H02 77 	U4167H03 88 	1.2 U4167H05				
WT5000-SD (MD, LD) WT500PD (PA, RD, RA)	U4173G21 90 	U4173L00 M14×2 	U4173G02 26 	U4173G01 88 	U5353V01 84 No.10 	U4173H01 88 No.10 	U4173H02 100 	



# AUTOMATIC TORCH

<BLUE TORCH II Series>

CO<sub>2</sub>/MAG



**4 Types Torch Heads are available for various work shapes**

- Curved neck with Fixed clamp Position
- Curved neck with Variable clamp Position
- Straight neck with Fixed clamp Position
- Straight neck with Variable clamp Position

● By the selection of "Clamp of Fixed Position" which has high-plasticity of positioning or "Clamp of Variable Position" which has the ability to achieve arbitrary position, big progress on efficiency of the work is possible.

**High Quality "FA TIP" is equipped as Standard**

- FA TIP restrains a wire aim deviation less than 0.1mm
- Well engineered contact tip's shape delivers improved gas shielding and it provides less spatter sticking

**Consumables are same as manual BLUE TORCH II Series.**

e.g., Insulator, Nozzle and Orifice

- The compatibility helps efficiency of the Inventory Control work



● **Standard Specifications of Blue Torch II Series**

	350A Type				500A Type			
MODEL PART NO.	WT350PD	WT350RD	WT350PA	WT350RA	WT500PD	WT500RD	WT500PA	WT500RA
RATED CURRENT	350A (CO <sub>2</sub> /MAG)				500A (CO <sub>2</sub> ) / 450A (MAG)			
APPLICABLE WIRE SIZE	(0.9)、(1.0)、1.2、(1.4) mm				(1.2)、1.4、(1.6) mm			
RATED DUTY CYCLE	60% (CO <sub>2</sub> ) / 35% (MAG)				60% (CO <sub>2</sub> ) / 30% (MAG)			
CABLE LENGTH	By 10 cm chopping fine from 1m to 6m *				By 10 cm chopping fine from 1m to 6m			
COOLING METHOD	AIR COOLED				AIR COOLED			

※ It isn't possible to use 0.9mm Wire by 3.1~4.5m Cable and use 0.9&1.0mm Wire by 4.6~6m Cable also.

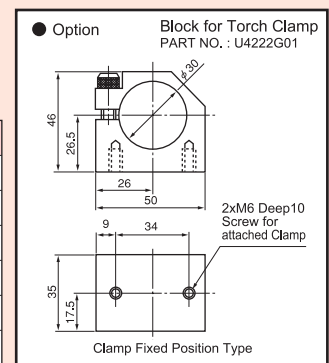

● **MODEL NUMBER of Automatic Blue Torch II Series**

**WT 350 P D - 15 D**

CO<sub>2</sub>/MAG  
Blue Torch II Series

RATED CURRENT  
350 : 350A  
500 : 500A

Clamp Positioning  
D : Fixed Position  
A : Variable Position

Torch Body Type  
P : Straight  
R : Curved

Cable Length \*2  
15 : 1.5m  
20 : 2.0m  
25 : 2.5m  
30 : 3.0m

**Wire Feeder Connection**  
D : DAIHEN  
DB : DAIHEN Black Torch \*1  
P : Panasonic  
E : Euro(Binzel)  
M : Miller  
MS : Miller (Separate GAS Hose)  
H : Hobart(Tweco)  
L : Lincoln  
FS : DAIDEN(FS Series)  
DM : DAIDEN(MOVE Series)  
HT : (Hitachi)

\*1. About DB : DAIHEN Black Torch Power Cable Adaptor, Guide Adaptor and Outlet Guide aren't included in Standard Set. Please use the parts of your Torch. If you want new parts, Please issue order up to your need by refer below parts.

Power Cable Adaptor	Outlet Guide	Guide Adaptor
U2853G00	U69B34 (0.9-1.2) U69B35 (1.2-1.6)	U785C13

\*2. By 10 cm chopping fine from 1m to 6m (Order Made)

WT350PD

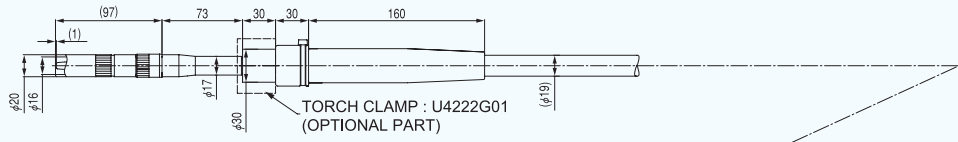

WT350RD

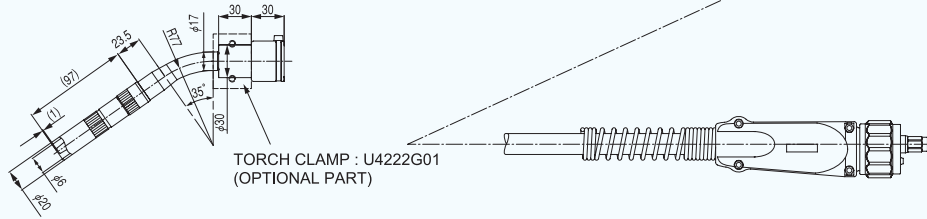

WT500PD

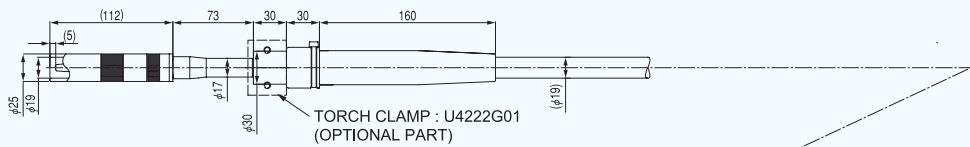

WT500RD

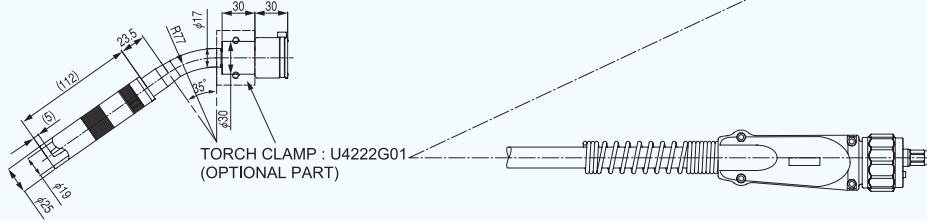

WT350PA

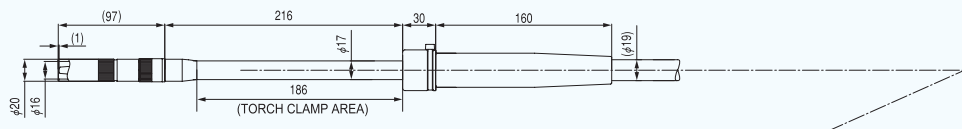

WT350RA

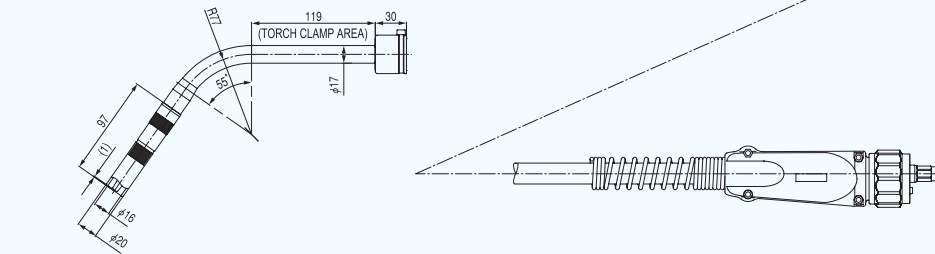

WT500PA

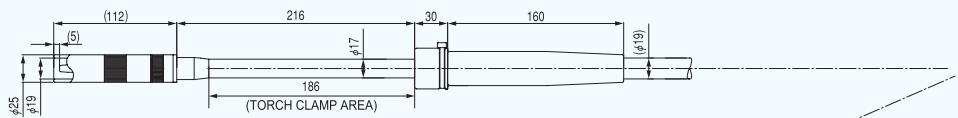

WT500RA

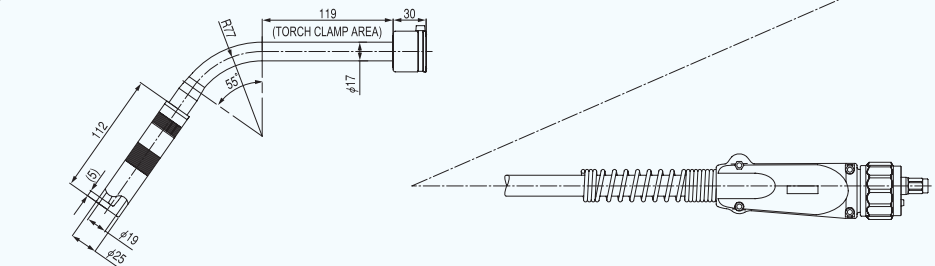

# Parts List for Blue Torch II Series

## Torch Body Combination list

(◎ Standard Parts ○ Optional Parts)

TORCH MODEL	TORCH BODY												
	R	55	76	77	100	115	130	55	76	77	100	115	130
	θ	45°						55°					
Part No.	U5020C00	U5339P00	U5339B00	U5339Q00	U5339C00	U5339R00	U5020B00	U5344B00	U5347B00	U5339E00	U5350B00	U5353B00	
*1 WT1800-SD	◎						○						
*1 WT2000-SD (MD)	◎						○						
*1 WT3500-SD (MD, LD)			○		○			◎			○		
*2 WT3510-SD (MD, LD)				○		○			◎			○	
*2 WT3520-SD (MD, LD)				○		○			○			◎	
*2 WT5000-SD (MD, LD)						○	○					○	◎

TORCH MODEL	TORCH BODY										
	Shapes	Straight				Flexible			Long Neck		
	Part No.	U5020S00	U5339G00	U5339H00	U5339J00	U5339S00	U5339K00	U5339L00	U5020Q00	U5339M00	U5339N00
*1 WT1800-SD		○				○			○		
*1 WT2000-SD (MD)		○				○			○		
*1 WT3500-SD (MD, LD)			○			○				○	
*2 WT3510-SD (MD, LD)				○				○			○
*2 WT3520-SD (MD, LD)					○			○			○
*2 WT5000-SD (MD, LD)					○						○
*1 WT2000F-SD (MD)						◎					
*1 WT3500F-SD (MD, LD)							◎				
*2 WT3510F-SD (MD, LD)								◎			
*2 WT3520F-SD (MD, LD)									◎		

## INNER LINER (OPTIONAL PART)

APPLICABLE WIRE SIZE	Part No.
0.6~0.9mm	U5003L69
0.8~1.2mm	U5003L82
1.2~1.6mm	U5003L26

\*Each INNER LINER can apply every Torch. Please choose up to Wire Size.

\*1. These Torches are possible to attach every Torch Body of WT1800, WT2000 & WT3500.  
\*2. These Torches are possible to attach every Torch Body of WT3510, WT3520 & WT5000.

## TIP

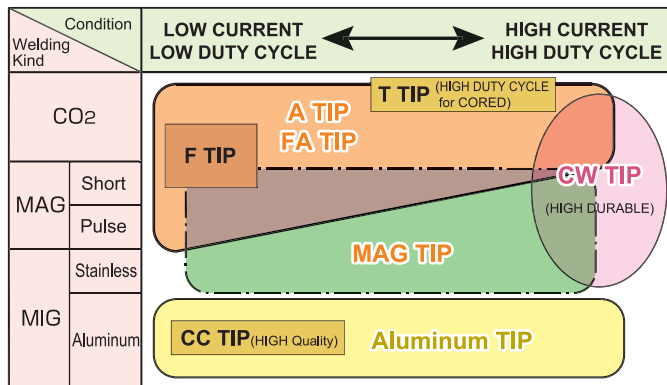

Wire Size	TIP	A TIP		FA TIP	T TIP	MAG TIP	CW TIP
		Solid	Cored	Automatic(Standard)	Cored		
0.6	—	K980B96	—	—	—	—	—
0.8	K980C02	K980C23	—	—	K662B13	—	—
0.9	K980C03	K980C24	—	L7250C02	K662B12	U4167H14	—
1.0	K980C04	K980C25	—	L7250C03	K980C17	U4167H13	—
1.2	K980C05	K980C26	K980C73	L7250C04	K980C19	U4167H12	K990E12
1.4	K980C06	K980C27	K980C74	L7250C05	K980C20	U4167H11	K990E14
1.6	K980C07	K980C28	—	L7250C06	K980C21	U4167H10	K990E16

Wire Size	TIP	Aluminum TIP		CC TIP		
		Air Cool:45L (WTA180,200)	Air Cool:45L (WTA300)	Water Cool:40L (WTAW400)	Air Cool:45L (WTA300)	Water Cool:40L (WTAW400)
0.8	—	K980C23	—	—	—	
1.0	—	K980C39	K980C36	—	K990C10	
1.2	—	K980C40	K980C37	K980B20	K990C12	K990B12
1.6	—	—	K980C38	K980B21	—	K990B16

### Long life & Durable Contact TIP for Steel: CW TIP

Inseted Tungsten Alloy at the edge of the Tip make advance provides in Mechanical Strength and Heat Resistance for a long life use

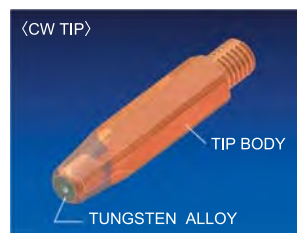

### High Quality contact TIP for Aluminum MIG: CC TIP

Forced power feeding method prevents poor power feeding, arc length change and current fluctuation and provides Stable Welding and Long Life Long Continue Welding is possible

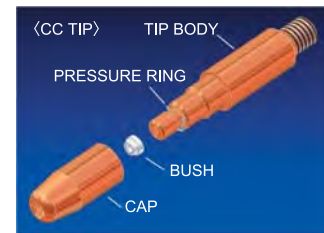

## Direct Plugs

- U5001D00 : OTC, Tokin
- U5001B00 : OTC Black Torch
- U5001P00 : Panasonic
- U5002E00 : Euro (Binzel)
- U5002M00 : Miller
- U5002S00 : Miller (Separate Gas Hose)
- U5002H00 : Hobart (Tweco)
- U5002L00 : Lincoln
- U5001F00 : DAIDEN FS Series
- U5001M00 : DAIDEM Move Series
- U5001H00 : Hitachi



### Head Office & Factory

60/86 Mu 19, Navanakorn Industrial Estate Phase3,  
Klong Nueng, Klong Luang, Pathumthani 12120 Thailand  
TEL : (+66) 2529-2130-1, 3335-8  
FAX : (+66) 2529-2132

### Bangkok (Sales) Office

23/43, Fl.16th Sorachai Bldg., 23 Soi Sukhumvit 63, Klongtonna, Wattana, Bangkok 10110 Thailand  
TEL : (+66) 2714-3201(Auto 5 Lines)  
FAX : (+66) 2714-3204  
E-mail : otcdai@otc.co.th URL : http://www.otcdaihenasia.com

Branch Office : Laemchabang

Representative Offices : India, Indonesia and Malaysia